

**Sumitomo Drive Technologies**  
*Always on the Move*

# Motion Control Drives

**FINE CYCLO®**

**F4C-D series**



No. F2002E-1

## Table of Contents

1. Construction.....	1
2. Application Examples.....	3
3. Nomenclature.....	4
4. Products.....	4
5. Speed Ratio & Rotation Direction.....	4
6. Operating Principles.....	5
7. Rating.....	6
8. Engineering Data.....	10
9. Main Bearings.....	13
10. Selection.....	14
11. Notice for Designing.....	16
12. Outline Drawing.....	19

Warranty Standard

Motion Control Drives  
FINE CYCLO®

# F4C-D series

**NEW**

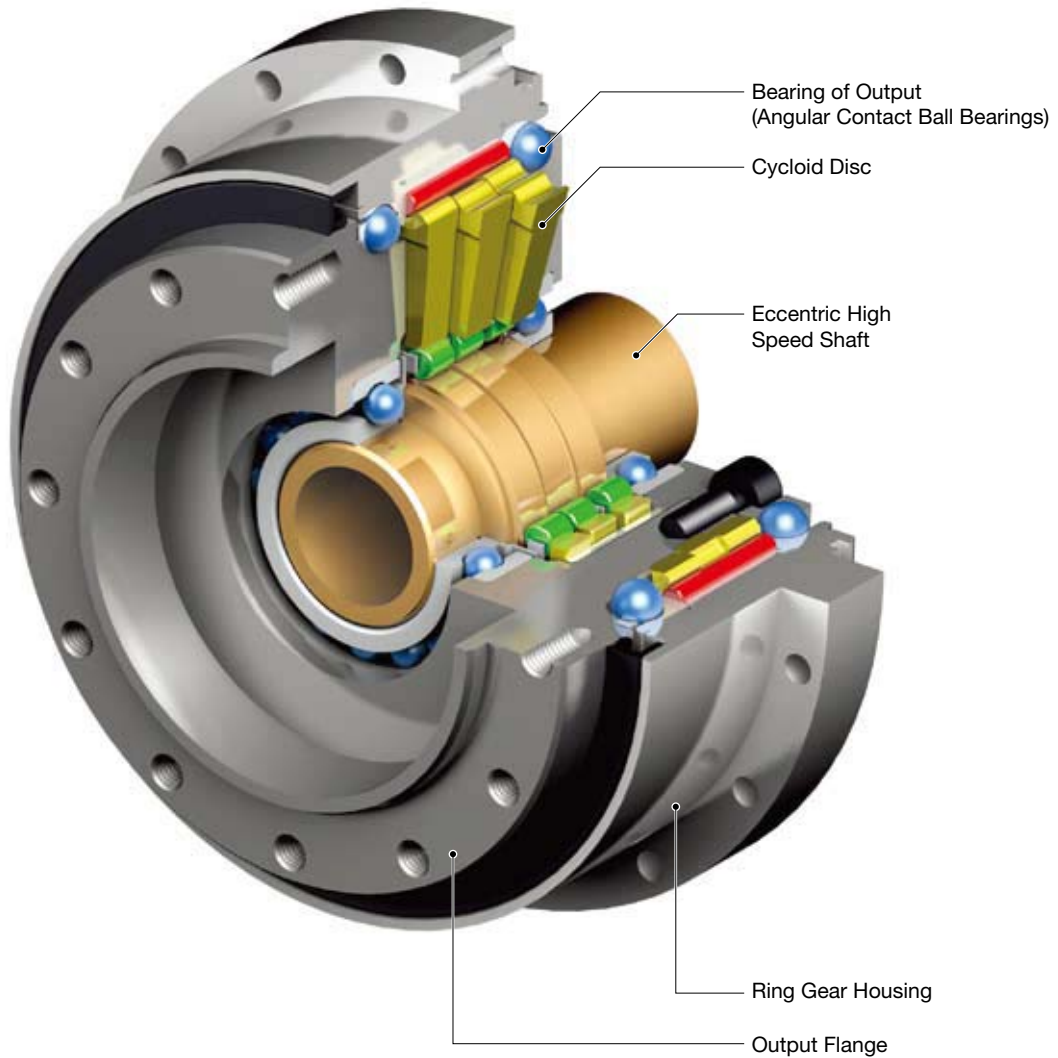

## Excellent Cost Performance

Simple construction with less number of parts than single stage reducer mechanism

## High Torque, High Allowable Moment Compact design

Allowable peak torque: Maximum 24% increase  
Allowable moment: Maximum 45% increase  
(Compared to traditional models)

## Reduces Man-Hour for Assembly

Flat output flange simplifies sealing process High-speed shaft supported by the reducer simplifies coupling with motor.

## New Model Enables Simpler Designing Improved Interface for Coupling Machines

Customer can choose the location of the attachment bolt on the output flange. This was done by the unified construction of the output flange and slow speed shaft pin.

## Large Hollow Diameter for the High-Speed Shaft

Reduced Length for Gearmotor Type  
Maximum 33% increase compared to the traditional high-speed hollow shaft.

# 1. Construction

Fig. D-1

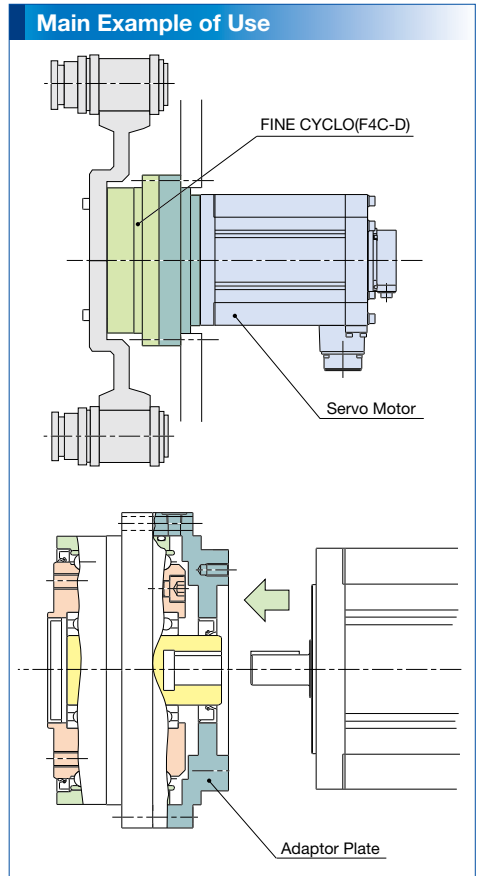
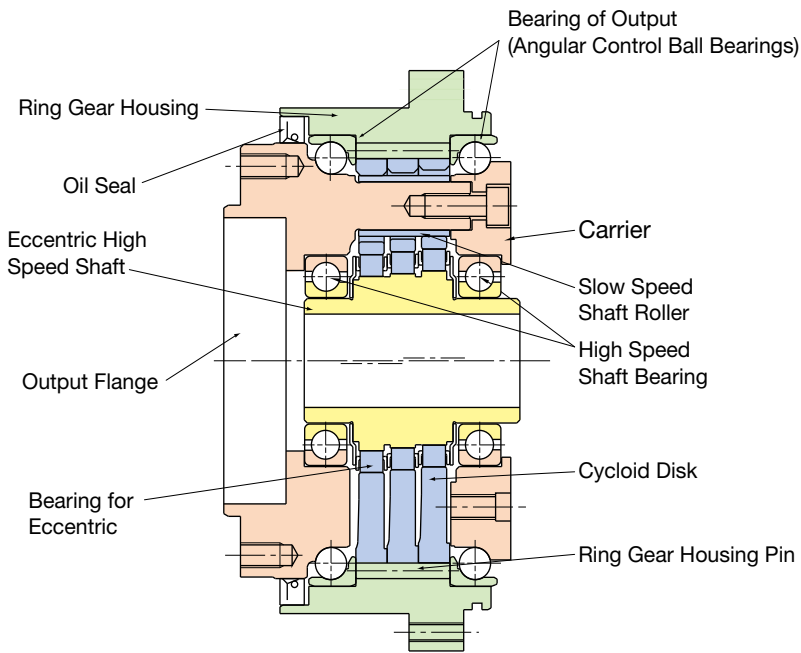

# 2. Application Examples

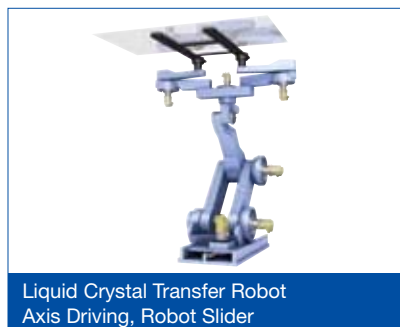
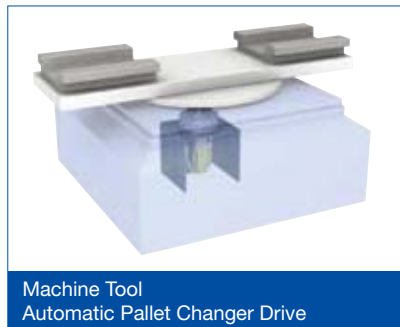
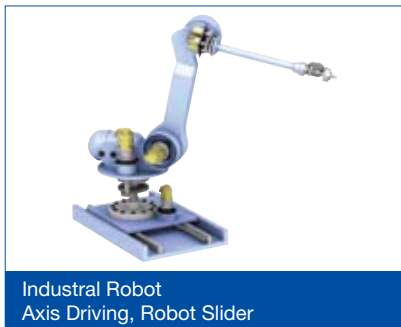

### 3. Nomenclature

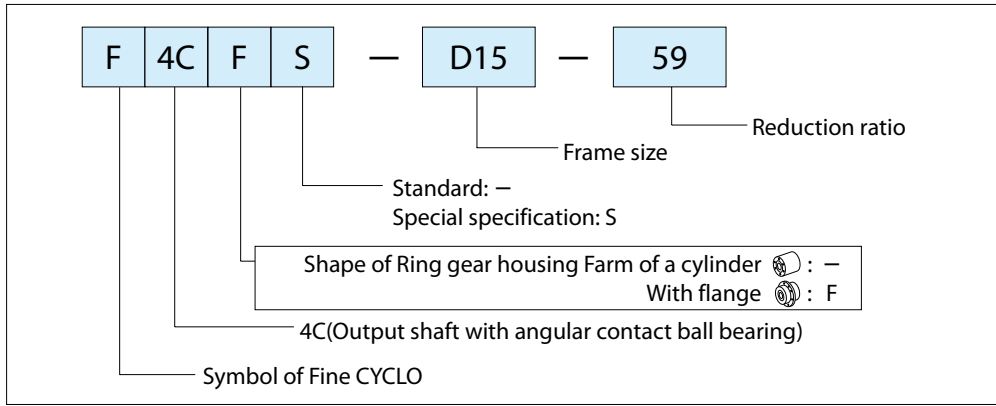

### 4. Products

Mark ●: Model Lineup

Frame size	Reduction ratio		
	59	89	119
D15	●	●	
D25	●	●	●
D30	●	●	●
D35	●	●	●
D45	●	●	●

### 5. Speed Ratio & Rotation Direction

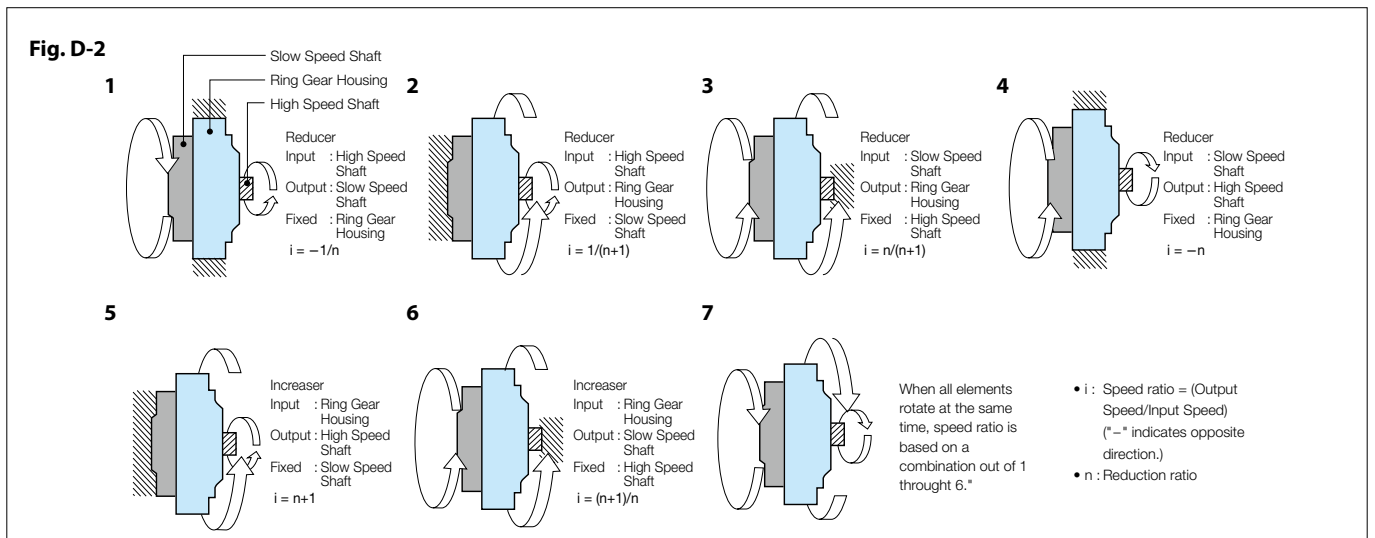

# 6. Operating Principles

The reducer portion of the FINE CYCLO® is fundamentally different in principle and mechanism from the involute gearing mechanism of competitive gearmotors. The unique speed reducer portion is an ingenious combination of the following two mechanisms:

- \* A combination of a planet gear and a fixed internal sun gear. In the FINE CYCLO®, the planet gear has cycloidal-shaped teeth and the sun gear has circular pin teeth. The number of teeth in the planet gear is one or two less than the sun gear.
- \* A constant speed internal gearing mechanism.

Fig. D-3 Principle of internal Planetary Gearing

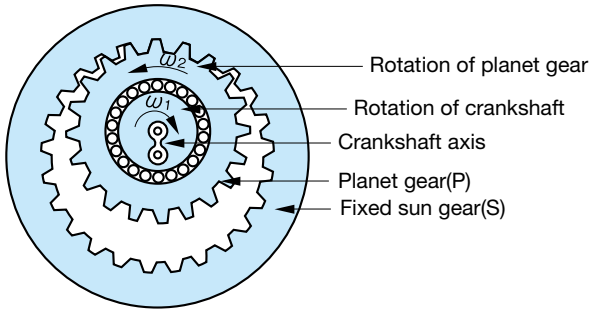

See Fig. D-3

In equation 1, below, P identifies the number of the planet gear teeth, S that of the sun gear, ω<sub>2</sub> the angular velocity of the planet gear around its own axis. The velocity ratio of ω<sub>2</sub> to ω<sub>1</sub> is shown as follows:

$$\frac{\omega_2}{\omega_1} = 1 - \frac{S}{P} = -\frac{S-P}{P} \text{---Equation 1}$$

With S greater by one or two than P in this equation, the highest velocity ratio is obtainable.

That is, if S-P=1 is applied to Equation 1, the velocity ratio may be calculated from the following equation:

$$\frac{\omega_2}{\omega_1} = \frac{1}{P} \text{---Equation 2}$$

Or if S-P=2 is applied to Equation 1, the velocity ratio may be calculated from the following equation:

$$\frac{\omega_2}{\omega_1} = \frac{2}{P} \text{---Equation 3}$$

As the crankshaft rotates at the angular velocity ω<sub>1</sub> around the axis of the sun gear, the planet gear rotates at the angular velocity:

$$-\frac{1\omega_1}{P} \text{ or } -\frac{2\omega_1}{P}$$

when P indicates the number of the teeth of the planet gear and the symbol indicates that the rotation of the planet gear is in a reverse direction to that of the crankshaft.

In the FINE CYCLO®, illustrated in Fig. D-4, circular teeth(pins) are adapted for the sun gear and epitrochoid curved teeth for the planet gear, thereby avoiding tooth top interference. The rotation of the planet gear around its own axis is taken out through a constant speed internal gearing mechanism as shown in Fig. D-5.

In this mechanism shown in Fig. D-6, the pins of the slow speed shaft are evenly spaced on a circle that is concentric to the axis of the sun gear. The pins transmit the rotation of the planet gear by rolling internally on the circumference of the bores of each planet gear or cycloid disc. The diameter of the bores minus the diameter of the slow speed shaft pins is equal to twice the eccentricity value of the crank shaft (eccentric). This mechanism smoothly transmits only the rotation of the planet gear around its own axis to the slow speed shaft.

Fig. D-4 Epitrochoid Planet Gear-Circular(PIN) Tooth Sun Gear Combination

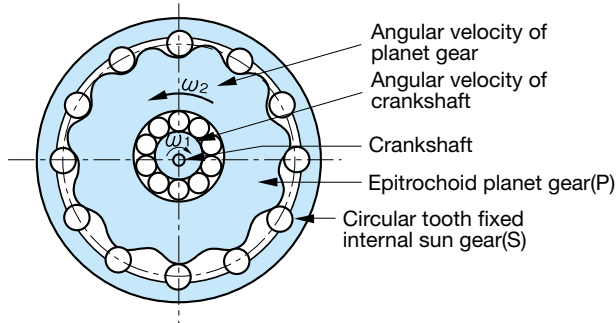

Fig. D-5 Constant Speed Internal Gearing

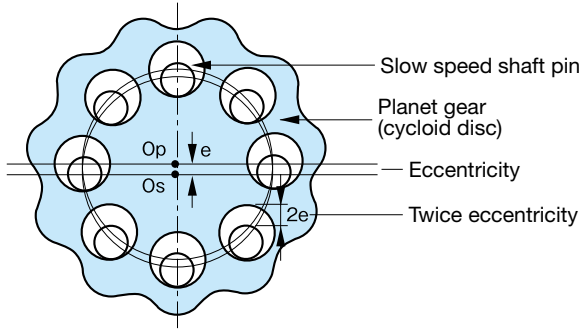
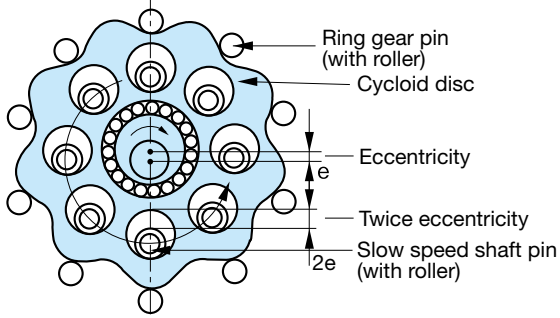

Fig. D-6 Combination of Planet-Sun Gears and Constant Speed Internal Gear



# 7. Rating

Table D-1 Rating Table (Output rotation base)

Output speed (r/min)		5			10			15			20			25		
Frame size	Reduction ratio	Rated output torque (Upper/N·m) (Lower/kgf·m)	Input speed (r/min)	Allowable input power (kW)	Rated output torque (Upper/N·m) (Lower/kgf·m)	Input speed (r/min)	Allowable input power (kW)	Rated output torque (Upper/N·m) (Lower/kgf·m)	Input speed (r/min)	Allowable input power (kW)	Rated output torque (Upper/N·m) (Lower/kgf·m)	Input speed (r/min)	Allowable input power (kW)	Rated output torque (Upper/N·m) (Lower/kgf·m)	Input speed (r/min)	Allowable input power (kW)
D15	59	226 23.0	295	0.15	226 23.0	590	0.30	201 20.5	885	0.39	184 18.8	1180	0.48	172 17.6	1475	0.56
	89	226 23.0	445	0.15	201 20.5	890	0.26	178 18.1	1335	0.35	163 16.6	1780	0.43	153 15.6	2225	0.50
D25	59	487 49.7	295	0.32	487 49.7	590	0.64	434 44.2	885	0.85	398 40.6	1180	1.04	372 38.0	1475	1.22
	89	487 49.7	445	0.32	433 44.1	890	0.57	383 39.0	1335	0.75	351 35.8	1780	0.92	329 33.5	2225	1.08
	119	487 49.7	595	0.32	396 40.4	1190	0.52	351 35.8	1785	0.69	322 32.8	2380	0.84	301 30.7	2975	0.99
D30	59	635 64.8	295	0.42	635 64.8	590	0.84	566 57.7	885	1.11	519 52.9	1180	1.36	486 49.5	1475	1.59
	89	635 64.8	445	0.42	565 57.6	890	0.74	500 51.0	1335	0.98	459 46.8	1780	1.20	429 43.7	2225	1.40
	119	635 64.8	595	0.42	517 52.7	1190	0.68	458 46.7	1785	0.90	420 42.8	2380	1.10	393 40.1	2975	1.29
D35	59	899 92	295	0.59	899 91.7	590	1.18	800 81.6	885	1.57	734 74.8	1180	1.92	686 70.0	1475	2.25
	89	899 92	445	0.59	798 81.4	890	1.05	707 72.1	1335	1.39	649 66.1	1780	1.70	607 61.8	2225	1.98
	119	899 91.7	595	0.59	732 74.6	1190	0.96	648 66.1	1785	1.27	594 60.6	2380	1.56	556 56.7	2975	1.82
D45	59	1756 179	295	1.15	1756 179	590	2.31	1565 160	885	3.07	1436 146	1180	3.76	1343 137	1475	4.39
	89	1756 179	445	1.15	1562 159	890	2.04	1383 141	1335	2.72	1269 129	1780	3.32	1180 121	2225	3.88
	119	1756 179	595	1.15	1431 146	1190	1.87	1267 129	1785	2.49	1162 118	2380	3.04			

Table D-2 Maximum acceleration or deceleration torque

Frame size	Maximum acceleration or deceleration torque		Peak torque for emergency stop	
	(N·m)	(kgf·m)	(N·m)	(kgf·m)
D15	417	42.5	834	85
D25	883	90	1766	180
D30	1226	125	2453	250
D35	1717	175	3581	365
D45	3188	325	6377	650

30			40			50			60			Allowable maximum input speed (r/min)	Allowable maximum output speed(r/min)		Equivalent On input shaft Upper/Moment of inertia ( $\times 10^4 \text{kg}\cdot\text{m}^2$ ) Lower/GD <sup>2</sup> ( $\times 10^4 \text{kgf}\cdot\text{m}^2$ )	Mass (kg)
Rated output torque (Upper/N·m) (Lower/kgf·m)	Input speed (r/min)	Allowable input power (kW)	Rated output torque (Upper/N·m) (Lower/kgf·m)	Input speed (r/min)	Allowable input power (kW)	Rated output torque (Upper/N·m) (Lower/kgf·m)	Input speed (r/min)	Allowable input power (kW)	Rated output torque (Upper/N·m) (Lower/kgf·m)	Input speed (r/min)	Allowable input power (kW)		50% ED	100% ED		
163 16.6	1770	0.64	150 15.3	2360	0.78	140 14.3	2950	0.92	133 13.5	3540	1.04	6150	5600	2800	0.38	5.2
145 14.7	2670	0.57	133 13.5	3560	0.69	124 12.6	4450	0.81	117 12.0	5340	0.92				0.37	
353 35.9	1770	1.38	323 33.0	2360	1.69	302 30.8	2950	1.98	286 29.2	3540	2.25	5050	4200	2100	1.55	8.1
311 31.7	2670	1.22	285 29.1	3560	1.49										1.54	
285 29.1	3570	1.12													1.53	
460 46.9	1770	1.81	422 43.0	2360	2.21	394 40.2	2950	2.58	373 38.1	3540	2.93	4550	3800	1900	3.99	11
406 41.4	2670	1.59	373 38.0	3560	1.95										3.96	
372 37.9	3570	1.46													3.95	
650 66.2	1770	2.55	596 60.8	2360	3.12	557 56.8	2950	3.65				3950	3300	1650	4.93	15
574 58.5	2670	2.25													4.89	
															4.87	
1271 130	1770	4.99	1166 119	2360	6.11							3150	2600	1300	12.51	24
															50.03	
															12.41	
															49.65	
															12.38	
															49.52	

: 50%ED range     : 100%ED range

Notes:

- Rated output torque  
Rated output torque implies allowable mean load torque at each output speed. Rated output torque for below 600r/min input is the same as 600r/min.  
Allowable input power is the value converted from rated output torque, when it is 100%. This value takes efficiency of FINE CYCLO<sup>®</sup> in consideration.
- Allowable maximum input speed and allowable mean input speed  
Reducer may be used within maximum input speed indicated in the Table, however, allowable mean input speed is limited by operation (%ED).
- Allowable acceleration or deceleration peak torque  
Allowable peak torque at normal start and stop.
- Allowable momentary maximum torque  
Allowable momentary maximum torque at emergency stop or heavy shock, when loading 1000 times in overall lifetime.
- Moment of inertia, GD<sup>2</sup>  
Value at input shaft. Divide them by g (Moment of inertia: 9.8m/sec<sup>2</sup>) or 4g (GD<sup>2</sup>: 4 x 9.8m/sec<sup>2</sup>) to convert from them to inertia.
- Calculate the rated torque using the following formula when the speed is not shown in the table above.

$$T_N = T_{15} \left( \frac{15}{N} \right)^{0.3}$$

T<sub>N</sub> : Rated torque when output speed N  
T<sub>15</sub>: Rated torque when output speed is 15r/min

Table D-3 Rating Table (Input rotation base)

Input speed (r/min)		4000			3000			2500			2000			1750		
Frame size	Reduction ratio	Rated output torque (Upper/N·m) (Lower/kgf·m)	Output speed (r/min)	Allowable input power (kW)	Rated output torque (Upper/N·m) (Lower/kgf·m)	Output speed (r/min)	Allowable input power (kW)	Rated output torque (Upper/N·m) (Lower/kgf·m)	Output speed (r/min)	Allowable input power (kW)	Rated output torque (Upper/N·m) (Lower/kgf·m)	Output speed (r/min)	Allowable input power (kW)	Rated output torque (Upper/N·m) (Lower/kgf·m)	Output speed (r/min)	Allowable input power (kW)
D15	59	128 13.0	67.8	1.13	139 14.2	50.8	0.93	147 15.0	42.4	0.82	157 16.1	a33.9	0.70	164 16.7	29.7	0.64
	89	128 13.0	44.9	0.75	139 14.2	33.7	0.61	147 15.0	28.1	0.54	157 16.1	22.5	0.46	164 16.7	19.7	0.42
D25	59	275 28.1	67.8	2.44	300 30.6	50.8	2.00	317 32.4	42.4	1.76	339 34.6	33.9	1.50	353 36.0	29.7	1.37
	89	275 28.1	44.9	1.62	300 30.6	33.7	1.32	317 32.4	28.1	1.16	339 34.6	22.5	1.00	353 36.0	19.7	0.91
	119	275 28.1	33.6	1.21	300 30.6	25.2	0.99	317 32.4	21.0	0.87	339 34.6	16.8	0.75	353 36.0	14.7	0.68
D30	59				392 40.0	50.8	2.61	414 42.3	42.4	2.30	443 45.2	33.9	1.96	461 47.0	29.7	1.79
	89				392 40.0	33.7	1.73	414 42.3	28.1	1.52	443 45.2	22.5	1.30	461 47.0	19.7	1.19
	119				392 40.0	25.2	1.29	414 42.3	21.0	1.14	443 45.2	16.8	0.97	461 47.0	14.7	0.89
D35	59				554 56.6	50.8	3.69	586 59.8	42.4	3.25	626 63.9	33.9	2.78	652 66.5	29.7	2.53
	89				554 56.6	33.7	2.44	589 59.8	28.1	2.15	626 63.9	22.5	1.84	652 66.5	19.7	1.68
	119							589 59.8	21.0	1.61	626 63.9	16.8	1.38	652 66.5	14.7	1.25
D45	59							1145 117	42.4	6.35	1224 125	33.9	5.43	1274 130	29.7	4.94
	89							1145 117	28.1	4.21	1224 125	22.5	3.60	1274 130	19.7	3.28
	119							1145 117	21.0	3.15	1224 125	16.8	2.69	1274 130	14.7	2.45

Table D-2 Maximum acceleration or deceleration torque

Frame size	Maximum acceleration or deceleration torque		Peak torque for emergency stop	
	(N·m)	(kgf·m)	(N·m)	(kgf·m)
D15	417	42.5	834	85
D25	883	90	1766	180
D30	1226	125	2453	250
D35	1717	175	3581	365
D45	3188	325	6377	650

1500			1000			750			600			Allowable maximum input speed (r/min)	Allowable maximum input speed(r/min)		Equivalent On input shaft Upper/Moment of inertia ( $\times 10^4 \text{kg}\cdot\text{m}^2$ ) Lower/GD <sup>2</sup> ( $\times 10^4 \text{kgf}\cdot\text{m}^2$ )	Mass (kg)
Rated output torque (Upper/Nm) (Lower/kgfm)	Output speed (r/min)	Allowable input power (kW)	Rated output torque (Upper/Nm) (Lower/kgfm)	Output speed (r/min)	Allowable input power (kW)	Rated output torque (Upper/Nm) (Lower/kgfm)	Output speed (r/min)	Allowable input power (kW)	Rated output torque (Upper/Nm) (Lower/kgfm)	Output speed (r/min)	Allowable input power (kW)		50% ED	100% ED		
171 17.5	25.4	0.57	194 19.8	16.9	0.43	211 21.5	12.7	0.35	226 23.0	10.2	0.30	6150	5600	2800	0.38	5.2
171 17.5	16.9	0.38	194 19.8	11.2	0.28	211 21.5	8.43	0.23	226 23.0	6.74	0.20				0.37	
370 37.7	25.4	1.23	418 42.6	16.9	0.93	455 46.5	12.7	0.76	487 49.7	10.2	0.65	5050	4200	2100	1.55	8.1
370 37.7	16.9	0.81	418 42.6	11.2	0.61	455 46.5	8.43	0.50	487 49.7	6.74	0.43				1.54	
370 37.7	12.6	0.61	418 42.6	8.4	0.46	455 46.5	6.30	0.38	487 49.7	5.04	0.32				1.53	
483 49.3	25.4	1.61	545 55.6	16.9	1.21	594 60.6	12.7	0.99	635 64.8	10.2	0.85	4550	3800	1900	3.99	11
483 49.3	16.9	1.06	545 55.6	11.2	0.80	594 60.6	8.43	0.66	635 64.8	6.74	0.56				3.96	
483 49.3	12.6	0.80	545 55.6	8.4	0.60	594 60.6	6.30	0.49	635 64.8	5.04	0.42				3.95	
683 69.7	25.4	2.27	771 78.7	16.9	1.71	840 85.8	12.7	1.40	899 91.7	10.2	1.20	3950	3300	1650	4.93	15
683 69.7	16.9	1.50	771 78.8	11.2	1.13	840 85.8	8.43	0.93	899 91.7	6.74	0.79				4.89	
683 69.7	12.6	1.13	771 78.6	8.40	0.85	840 85.8	6.30	0.69	899 91.7	5.04	0.59				4.87	
1334 136	25.4	4.44	1507 154	16.9	3.34	1643 168	12.7	2.73	1756 179	10.2	2.34	3150	2600	1300	12.51	24
1334 136	16.9	2.94	1507 154	11.2	2.22	1643 168	8.43	1.81	1756 179	6.74	1.55				12.41	
1334 136	12.6	2.20	1507 154	8.40	1.66	1643 168	6.30	1.35	1756 179	5.04	1.16				12.38	

□ : 50%ED range □ : 100%ED range

Notes:

- Rated output torque  
Rated output torque implies allowable mean load torque at each output speed. Rated output torque for below 600r/min input is the same as 600r/min.  
Allowable input power is the value converted from rated output torque, when it is 100%. This value takes efficiency of FINE CYCLO<sup>®</sup> in consideration.
- Allowable maximum input speed and allowable mean input speed  
Reducer may be used within maximum input speed indicated in the Table, however, allowable mean input speed is limited by operation (%ED).
- Allowable acceleration or deceleration peak torque  
Allowable peak torque at normal start and stop.
- Allowable momentary maximum torque  
Allowable momentary maximum torque at emergency stop or heavy shock, when loading 1000 times in overall lifetime.
- Moment of inertia, GD<sup>2</sup>  
Value at input shaft. Divide them by g (Moment of inertia: 9.8m/sec<sup>2</sup>) or 4g (GD<sup>2</sup>: 4 x 9.8m/sec<sup>2</sup>) to convert from them to inertia.
- Calculate the rated torque using the following formula when the speed is not shown in the table above.

$$T_N = T_{1750} \left( \frac{1750}{N} \right)^{0.3}$$

T<sub>N</sub> : Rated torque when output speed N

T<sub>1750</sub>: Rated torque when output speed is 1750r/min

# 8. Engineering Data

## 8-1. Stiffness and lost motion

- Hysteresis curve : Relationship between load and displacement of output flange (rotational angle) when load is removed slowly from allowable torque to zero torque, with fixed input shaft.
- Lost Motion : Torsional deflected angle at ±3% of allowable output torque.
- Stiffness : Slope of the straight line connecting two points, when allowable torque is 50% and 100% on the hysteresis curve.

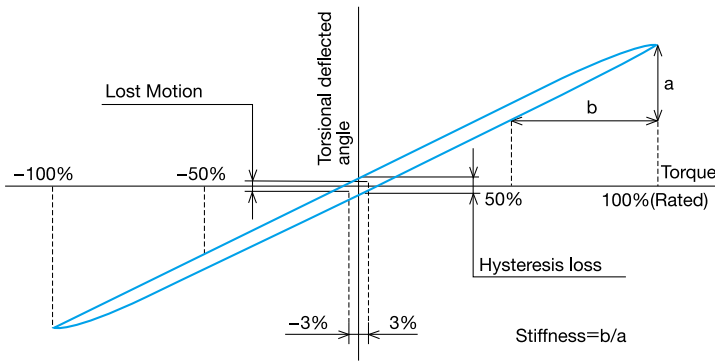

Fig. D-7 Hysteresis curve

## 8-2. No Load Running Torque

No load running torque indicates torque on input shaft for rotating reducer under no-load condition.

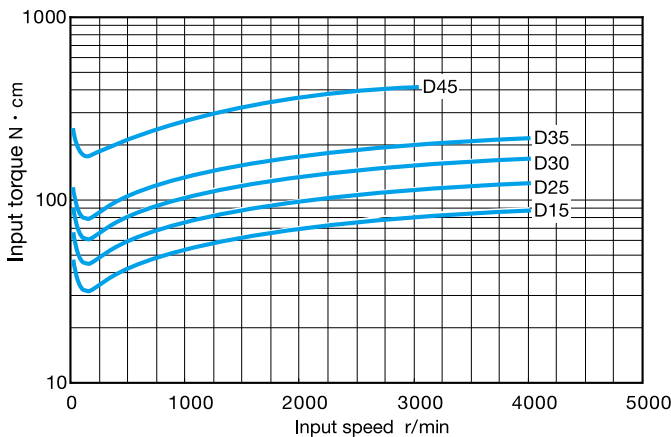

Fig. D-8

- Notes) 1. Fig. D-8 shows average data after reducers have been run.  
2. Measurement Conditions

Ring gear housing temperature	Approx. 30°C
Accuracy in assembled dimensions	Refer to 11.1
Lubrication	Standard grease

Table D-4 Engineering data

Frame size	Rated output torque	Lost Motion		Stiffness Up: Nm/arc min Down: kgfm/arc min
		Measured torque (±) Up/ Nm Down/ kgfm	Lost Motion arc min	
D15	59	6.03 0.62	1.0	49.0 5.0
	89	5.34 0.54		
D25	59	13.0 1.33		112 11.4
	89	11.5 1.17		
	119	10.5 1.07		
D30	59	17.0 1.73		173 17.7
	89	15.0 1.53		
	119	13.7 1.40		
D35	59	24.0 2.45		220 22.4
	89	21.2 2.16		
	119	19.4 1.98		
D45	59	47.0 4.79		450 45.9
	89	41.5 4.23		
	119	38.0 3.88		

Note) Arc min means "minute" of the angle. Stiffness is the average value (typical data).

### (Example calculation of torsional deflected angle)

Calculation of torsion angle when torque is applied in one direction using D35-59 as example.

- 1) When load torque is 15N·m  
(When load torque is in the range of lost motion)

$$\theta = \frac{15}{24} \times \frac{1}{2} = 0.31 \text{ arcmin}$$

- 2) When load torque is 600N·m

$$\theta = \frac{1}{2} \times \frac{600-24}{220} = 3.1 \text{ arcmin}$$

### 8-3. No-Load Friction Torque on Output Shaft

Indicates torque necessary to start rotation from output side of reducer from stop without load.

Table D-5 Value of no-load friction torque on output shaft

Frame size	No-load friction torque on output shaft	
	N·m	kg·m
D15	34	3.5
D25	60	6
D30	72	7
D35	88	9
D45	167	17

Notes: 1. Table D-5 shows average data after reducers have been run.  
2. Measurement Conditions

Accuracy in assembled dimensions	Refer Item 11-1
Lubrication	Standard grease

### 8-4. Efficiency

Fig. D-9 Efficiency Curve

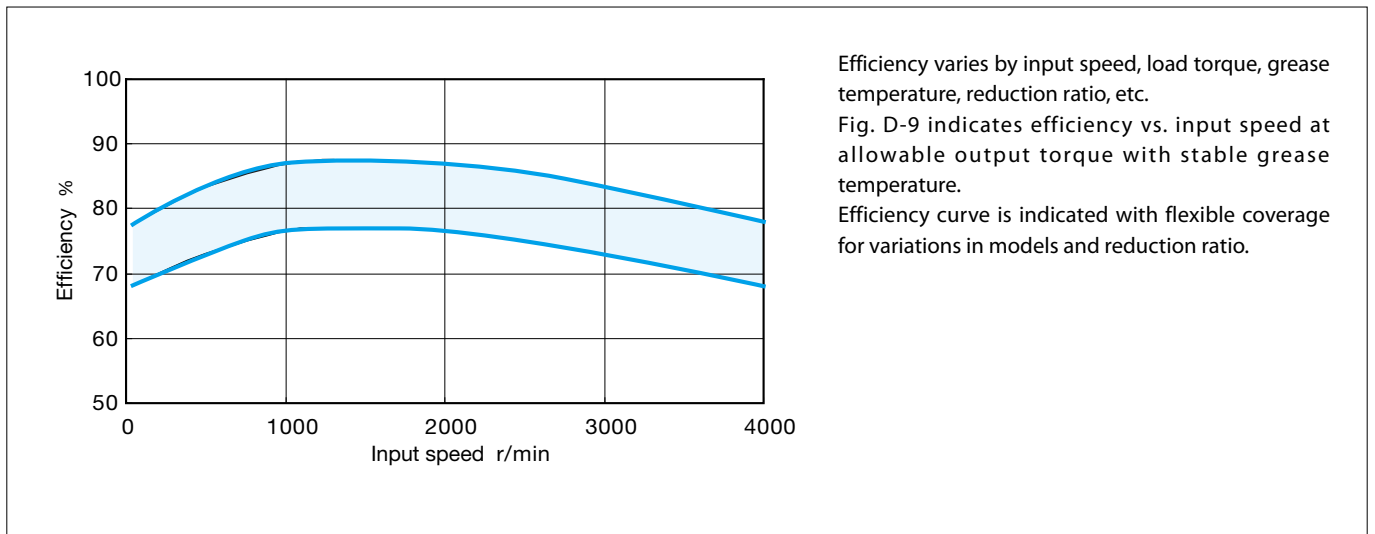
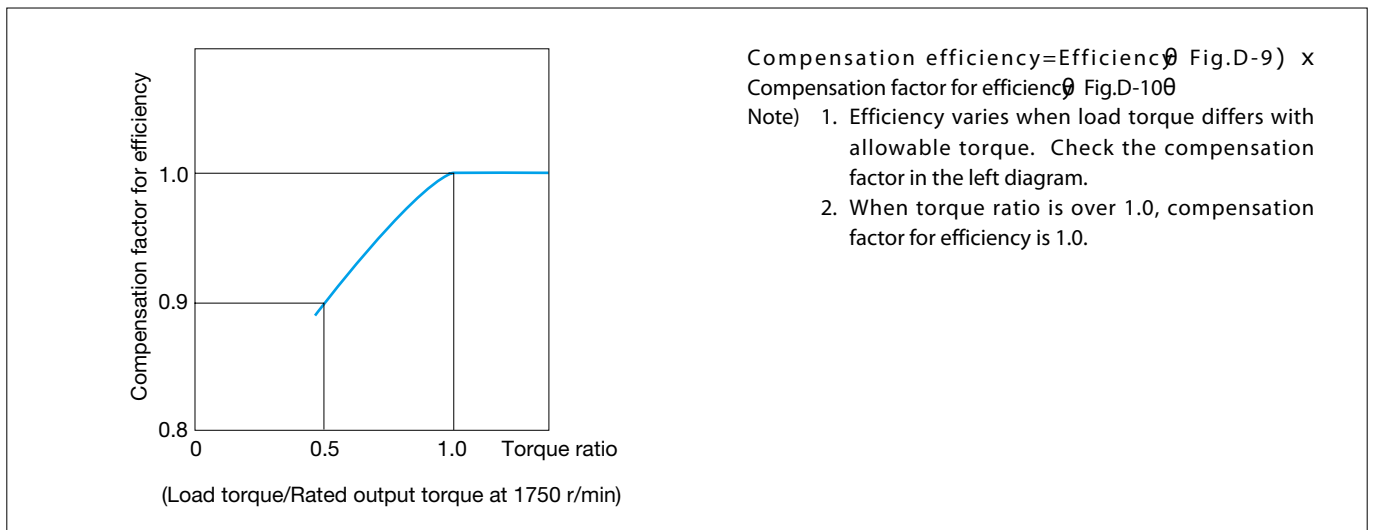

Fig. D-10 Compensation Curve of Efficiency



### 8-5. ALLOWABLE RADIAL LOAD & AXIAL LOAD OF HIGH SPEED SHAFT

When a gear or sheave is mounted on the high speed shaft, radial load and axial load should be equal to or less than allowable value. Check radial & axial load by following the next formula ( ① ~ ② ).

① Radial load  $P_r$

$$P_r = \frac{T\ell}{R} \leq \frac{P_{ro}}{L_f \cdot C_f \cdot F_{S1}} \quad [\text{N, kgf}] \quad (\text{Formula D-1})$$

② Axial load  $P_a$

$$P_a \leq \frac{P_{ao}}{C_f \cdot F_{S1}} \quad [\text{N, kgf}] \quad (\text{Formula D-2})$$

③ When radial and axial load co-exist

$$\left( \frac{P_r \cdot L_f}{P_{ro}} + \frac{P_a}{P_{ao}} \right) \cdot C_f \cdot F_{S1} \leq 1 \quad (\text{Formula D-3})$$

$P_r$  : Actual radial load [N, kgf]

$T\ell$  : Equivalent torque on input shaft [N·m, kgfm]

$R$  : Pitch circle radius of sprocket, gear, or sheave [m]

$P_{ro}$  : Allowable radial load [N, kgf] (Table D-6)

$P_a$  : Actual axial load [N, kgf]

$P_{ao}$  : Allowable axial load [N, kgf] (Table D-7)

$L_f$  : Load location factor (Table D-8)

$C_f$  : Coupling factor (Table D-9)

$F_{S1}$  : Shock factor (Table D-10)

Table D-6 Actual radial load  $P_{ro}$  (Up: N/Down: kgf)

Frame size	Input speed r/min								
	4000	3000	2500	2000	1750	1500	1000	750	600
D15	226	245	265	284	294	314	353	392	422
	23	25	27	29	30	32	36	40	43
D25	334	373	392	422	441	461	530	589	628
	34	38	40	43	45	47	54	60	64
D30		432	461	500	520	549	628	687	746
		44	47	51	53	56	64	70	76
D35		491	520	559	589	618	706	785	844
		50	53	57	60	63	72	80	86
D45			608	657	687	726	824	912	981
			62	67	70	74	84	93	100

Calculate the actual radial load using the following formula when the speed is not shown in the table above.

$$P_{rN} : P_{r1750} \left( \frac{1750}{N} \right)^{1/3}$$

$P_{rN}$  : Actual radial load when input speed N

$P_{r1750}$  : Actual radial load when input speed 1750r/min

Table D-7 Actual axial load  $P_{ao}$  (Up: N/Down: kgf)

Frame size	Input speed r/min								
	4000	3000	2500	2000	1750	1500	1000	750	600
D15	245	284	314	343	363	392	471	549	608
	25	29	32	35	37	40	48	56	62
D25	363	412	451	500	540	579	697	804	883
	37	42	46	51	55	59	71	82	90
D30		520	569	638	677	726	883	1001	1118
		53	58	65	69	74	90	102	114
D35		540	589	657	706	755	922	1059	1167
		55	60	67	72	77	94	108	119
D45			1010	1118	1197	1295	1570	1795	2001
			103	114	122	132	160	183	204

Calculate the actual axial load using the following formula when the speed is not shown in the table above.

$$P_{aN} : P_{a1750} \left( \frac{1750}{N} \right)^{0.47}$$

$P_{aN}$  : Actual axial load when output speed N

$P_{a1750}$  : Actual axial load when output speed 1750r/min

Table D-8 Load Location Factor  $L_f$

L (mm)	Frame size				
	D15	D25	D30	D35	D45
10	0.91	0.87			
15	0.99	0.94	0.92	0.91	
20	1.25	1.00	0.98	0.97	0.90
25	1.56	1.25	1.14	1.09	0.94
30	1.88	1.50	1.36	1.30	0.99
35	2.19	1.75	1.59	1.52	1.13
40		2.00	1.82	1.74	1.29
45			2.05	1.96	1.45
50				2.17	1.61
60					1.94
$L_f = \text{When 1 of L (mm)}$	16	20	22	23	31
a	0.072	0.063	0.061	0.055	0.046

$L \geq L_1$   $L_f = L/L_1$   $L_1$ :  $L_f = \text{When 1 of L}$

$L < L_1$   $L_f = 1.0 - a/5 \times (L_1 - L)$

Table D-9 Coupling Factor  $C_f$

Coupling method	$C_f$
Chain	1
Machine gear or pinion	1.25
Timing belt	1.25
V-Belt	1.5

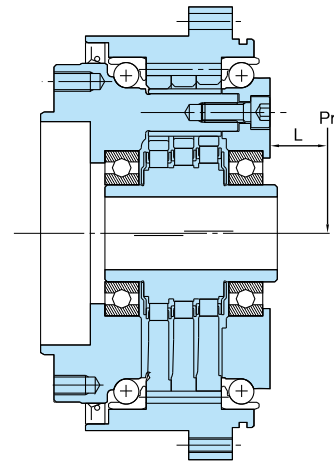

Fig. D-11 Load location on input shaft

Table D-10 Shock Factor  $F_{S1}$

Degree of shock	$F_{S1}$
Practically no shock	1
Light shock	1~1.2
Severe shock	1.4~1.6

# 9. Main Bearings

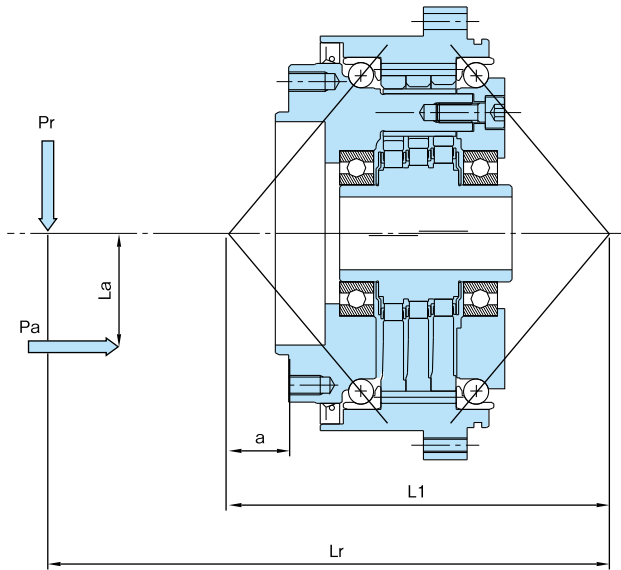

Fig. D-12 Span between each loading point  
 Note) Consult us if:  $L_r > 4 \times L_1$

Pr: Actual radial load (N, kgf)  
 Pa: Actual axial load (N, kgf)

Table D-11 Span of Loading Points (mm)

Frame size	Span of Loading Points	
	L1(mm)	a(mm)
D15	119	23.6
D25	139	23.4
D30	157	24.5
D35	170	40.5
D45	206	52.4

Table D-12 Moment Stiffness

Frame size	Moment Stiffness	
	(N·m/arcmin)	(kgf·m/arcmin)
D15	510	52
D25	833	85
D30	1127	115
D35	1470	150
D45	2450	250

Table D-13 Allowable Moment & Allowable Axial Load

Frame size	Allowable Moment		Allowable Axial Load	
	(N·m)	(kgf·m)	(N)	(kgf)
D15	883	90	3924	400
D25	1177	120	3924	400
D30	1668	170	5199	530
D35	1962	200	7848	800
D45	2943	300	10791	1100

1. Moment Stiffness  
 Indicates stiffness on inclination of output shaft with external moment.

External moment (M)  
 $M = Pr \cdot L_r + Pa \cdot L_a$  ..... (Formula D-4)

2. Allowable Moment & Allowable Axial Load  
 Check external moment and external axial load with Formula D-5, Formula D-6, and Fig.D-13.

Equivalent moment (Me)  
 $Me = C_f F_{S1} Pr L_r + C_f F_{S1} Pa \cdot L_a$  ..... (Formula D-5)

Equivalent axial load (Pae)  
 $Pae = C_f F_{S1} Pa$  ..... (Formula D-6)

Cf: Coupling factor [Table D-14]  
 F<sub>S1</sub>: Shock factor [Table D-15]

Table D-14 Coupling Factor Cf

Load connection factor	Cf
General purpose chain	1
Machine gear or pinion	1.25
Timing belt	1.25
V-Belt	1.5

Table D-15 Shock factor F<sub>S1</sub>

Load Classification	F <sub>S1</sub>
Uniform load (no shock)	1
Moderate shocks	1~1.2
Heavy shocks	1.4~1.6

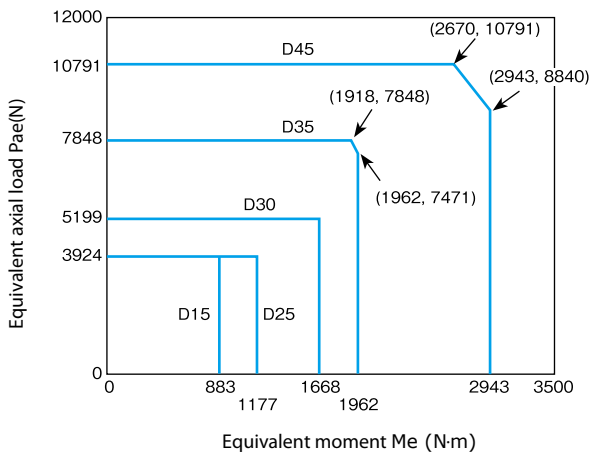
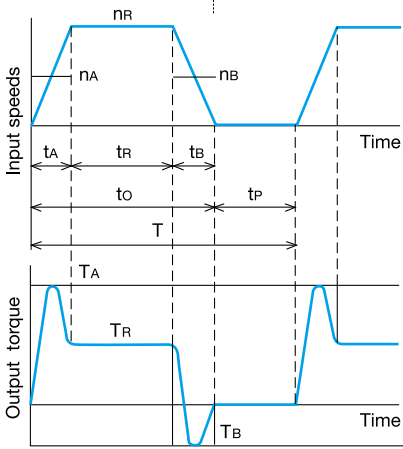

Fig. D-13 Diagram of Allowable Moment & Axial Load

# 10. Selection

## 10-1. Flow Cart and Formula of Selection

FIG. D-14 Load cycle



- $n_A$  : Average input speed during acceleration under condition defined in Fig. D-14  

$$n_A \theta = \frac{n_R}{2}$$
- $n_R$  : Input speed with normal running
- $n_B$  : Average input speed during deceleration in Fig. D-14  

$$n_B \theta = \frac{n_R}{2}$$
- $t_A$  : Acceleration time
- $t_R$  : Normal running time
- $t_B$  : Deceleration time
- $t_o$  : Total running time
- $t_P$  : Standstill time
- $T$  : Time/Cycle
- $T_A$  : Acceleration peak torque
- $T_R$  : Torque during normal running
- $T_B$  : Peak torque at braking

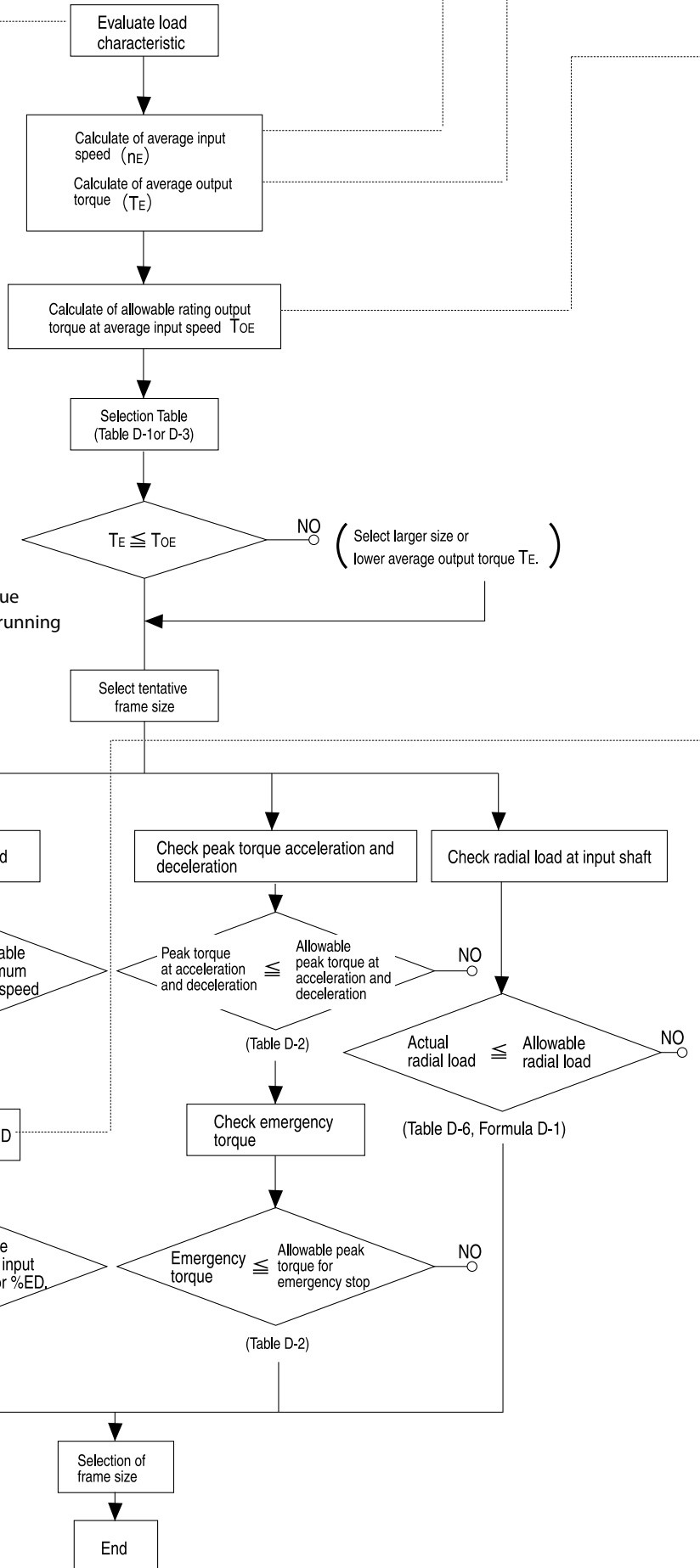

Calculation in Load Condition of Fig. D-14

○ Average input speed  $n_E = \left( \frac{t_A n_A + t_R n_R + t_B n_B}{t_o} \right)$  ..... (Formula D-8)

○ Average output torque  $T_E = \left( \frac{t_A n_A T_A^{10/3} + t_R n_R T_R^{10/3} + t_B n_B T_B}{t_o} \right)^{0.3} \times F_{S2}$  ..... (Formula D-9)

○ Allowable rating output torque at average input speed  $T_{OE} = \left( \frac{600}{n_E} \right)^{0.3} \times T_o$  ..... (Formula D-10)

To: Rated output torque at input speed 600r/min (Table D-3)  
When  $n_E < 600$ ,  $T_{OE}$  equals to  $T_o$  at input speed 600r/min.

○ %ED.....  $ED = \frac{t_o}{T} \times 100$  ..... (Formula D-10)

Maximum of single cycle time is 10 minutes when calculating %ED. When single cycle time is over 10 minutes, calculate %ED as  $T=10$  (minutes).

Table D-16  $F_{S2}$  Load factor

Loading condition	$F_{S2}$
Uniform load	1
Moderate shock	1~1.2
Heavy shock	1.4~1.6

10-2. Example of Selection

Evaluate F4CF-D25-119 for following specification.

(Specification) $T_A$ : Acceleration peak torque	600N·m	$t_A$ : Acceleration time	0.3sec
$T_R$ : Normal running torque	250N·m	$t_R$ : Normal running time	3.0sec
$T_B$ : Peak torque at breaking	400N·m	$t_B$ : Deceleration time	0.3sec
Emergency torque : 1700N·m		$t_P$ : Total running time	3.6sec
(1000 times during overall life time)		$t_o$ : Standstill time	3.6sec
$n_A$ : Average input speed during acceleration	1250r/min	$T$ : Single cycle time	7.2sec
$n_R$ : Input speed with normal running	2500r/min	Radial load at input shaft	: Operated by timing belt with moderate shock 196N at point 25mm from end of shaft
$n_B$ : Average input speed during deceleration	1250r/min	Radial load at output shaft	: Connection with gear, moderate shock 4116N at 60mm point from side of flange

It considered that reducer is used to operate wrist of robot with moderate shock.

(Calculate) Average input speed  $n_E = \frac{0.3 \times 1250 + 3.0 \times 2500 + 0.3 \times 1250}{3.6} = 2292$ (r/min)

Average output torque  $T_E = \left( \frac{0.3 \times 250 \times 600^{10/3} + 3.0 \times 2500 \times 250^{10/3} + 0.3 \times 1250 \times 400^{10/3}}{3.6 \times 2292} \right) \times 1 = 306$ (N·m)

○ Allowable output torque at average input speed  $T_{OE} = \left( \frac{600}{2292} \right)^{0.3} \times 487 = 326$ (N·m)  $\geq 306$ (N·m) → F4CF—D25—119

○ Calculate of % ED  $\%ED = \frac{3.6}{7.2} \times 100 = 50\%$

○ Evaluate of maximum input speed 2500(r/min) < 5050(r/min) (Table D-1or D-3)

○ Evaluate of average input speed 2292(r/min) at 50%ED < 4200(r/min) at 50%ED (Table D-1or D-3)

○ Evaluate of peak torque at acceleration and deceleration 600(N·m) < 883(N·m) (Table D-2)

○ Evaluate of emergency torque 1700(N·m) < 1766(N·m)(with dowel pins) (Table D-2)

○ Allowable radial load at input shaft with coefficient in consideration

$Pro = 402N = 441 \times (1750/2292)^{1/3}$ ,  $Lf = 1.25$ ,  $Cf = 1.25$ ,  $F_{S1} = 1.2$

$\frac{Pro}{Lf \times Cf \times F_{S1}} = \frac{420}{1.25 \times 1.25 \times 1.2} = 214$ (N) > 196(N) (Table D-6, Fomula D-1)

○ Evaluate of allowable moment

$Lr = 55 + L1 - a = 55 + 139 - 23.4 = 175.6$

External Moment Calculated with the Coefficient

$Cf = 1.25$ ,  $F_{S1} = 1.2$ ,  $M = Cf \times F_{S1} \times Pr \times Lr = 1.25 \times 1.2 \times 4116 \times 175.6 = 1084$ (N·m) < 1177(N·m)

F4CF-D25-119 is selected by evaluation above.

# 11. Notice for Designing

## 11-1 Precision in Assembly Dimensions

Fig. D-15 Method of Assembly

- Pilot for mounting input parts (motor etc.) are as (C) in following figure.
- Use (B) for output shaft assembly and (A) for casing assembly as pilot for mounting.

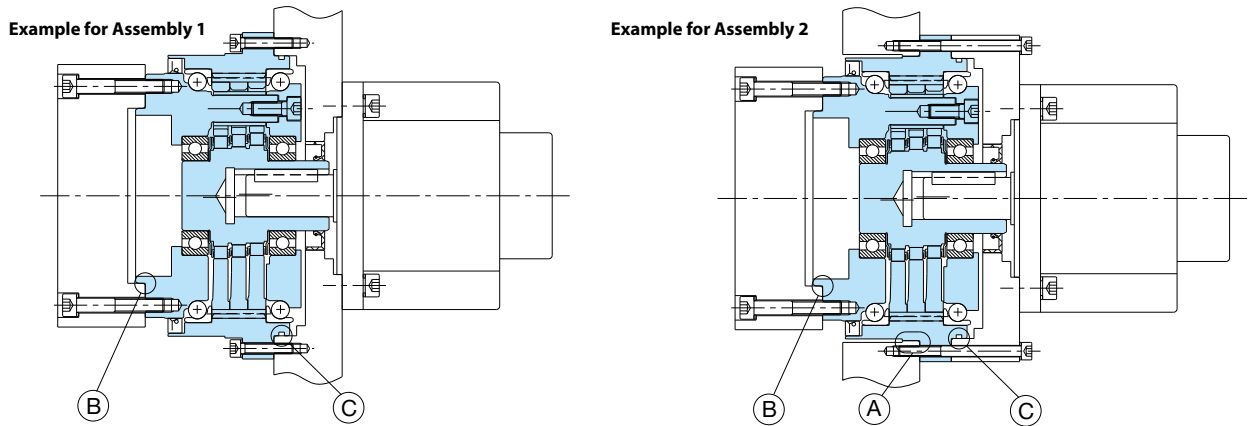

Fig. D-16 Precision in assembly dimensions

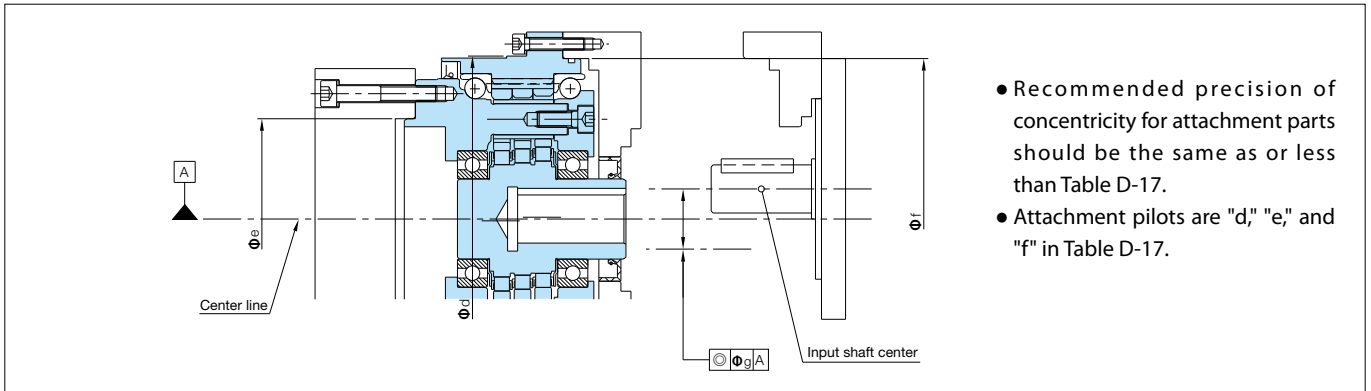

Table D-17

Frame size	d	e	f	g
D15	124H7/h7	47H7/h7	123H7/h7	0.03
D25	145H7/h7	80H7/h7	145H7/h7	0.03
D30	163H7/h7	100H7/h7	160H7/h7	0.03
D35	174H7/h7	75H7/h7	174H7/h7	0.03
D45	220H7/h7	100H7/h7	220H7/h7	0.03

## 11-2. Tightening Torque and Allowable Transmitted Torque for Bolts

(1) Allowable transmitted torque for bolts

Quantity, size, and tightening torque of bolt for the output flange and ring gear housing are shown in Table D-18. Allowable peak torque for emergency stop that can be transmitted is shown in Table D-19.

Table D-18

Frame size	Output Flange Bolts			Ring gear housing bolts		
	Number of bolts-size	Tightening torque		Number of bolts-size	Tightening torque	
		N·m	kgf·cm		N·m	kgf·cm
D15	12—M8	38.3	390	12—M6	15.7	160
D25	12—M8	38.3	390	16—M6	15.7	160
D30	16—M8	38.3	390	16—M6	15.7	160
D35	12—M10	76.5	780	16—M8	38.3	390
D45	16—M12	133	1360	16—M10	76.5	780

Table D-19

Frame size	Allowable transmitted torque by bolts	
	N·m	kgf·m
D15	1478	151
D25	2065	211
D30	2786	284
D35	3962	404
D45	9347	954

- Bolt: Use metric hexagon socket head cap screw based on JIS B1176, strength grade 12.9"
- Countermeasure for bolts loosening: Use adhesives (Loctite262, etc.) or spring washer (based on JIS B1252, class 2).
- Use conical spring washer (Based on JIS B1252, class 2) on flange side when coupling the reducer to prevent damaging the bolt bearing surface.

- Friction Coefficient: 0.15

### 11-3. Assembly Procedure

⊖

**Example for Assembly 1**

CYCLO F-Series is attached to the casing of machine with bolts.  
 Motor adaptor is a part of the casing in this example.  
 Please consider and select the construction.  
 The lubricant must be sealed between the motor adaptor plate and eccentric high speed shaft.

Casing of machine

C

⊖

**Example for Assembly 2**

CYCLO F-Series is attached to the casing of machine with bolts.  
 (Pilot: A)  
 If attaching motor adapter plate, bolt together with reducer part.  
 The lubricant must be sealed between the motor adaptor plate and eccentric high speed shaft.

Motor adaptor plate

Casing of machine

A

C

⊖

Match the phase of motor shaft and input shaft of reducer. Attach motor to reducer parts with bolts.  
 (Apply prevention agent for fretting to motor shaft before assembly.)

⊖

Match the phase of motor shaft and input shaft of reducer. Attach motor to reducer parts with bolts.  
 (Apply prevention agent for fretting to motor shaft before assembly.)

⊗

Output flange

Assembly surface: b

B

Attach output flange of CYCLO to output shaft of machine by bolts.  
 (Pilot: B)  
 Apply liquid gasket to the assembly side "b" at this point.

⊗

Output flange

Assembly surface: b

B

Attach output flange of CYCLO to output shaft of machine by bolts.  
 (Pilot: B)  
 Apply liquid gasket to the assembly side "b" at this point.

Notes1) Make sure to apply specified tightening torque( refer to Table D-18) to bolts when attaching reducer.  
 Notes2) Choose bolts shorter than the depth of tap indicated in output side flange in Outline Drawing (P19-P20), when attaching output shaft to output side flange (slow speed shaft)of CYCLO DRIVE.  
 Recommended liquid gasket: Liquid gasket Three Bond 1215 of Three Bond Co., Ltd.

## 11-4. Lubrication

- F4CF-D-Series are shipped with grease drained at the time of shipment. Customer must prepare and fill appropriate amount of (Table D-20) recommended grease (Table D-21).
- Use quantity indicated in Table D-21 as a guide, check the actual grease level when filling grease.
- Match the position of filler and drain port at output side with one of eccentric planetary shaft bearing. (See "'A'" in Fig.D-17 and Table D-20)"
- When supplying with grease for the first time, fill from lower drain port to ensure grease circulation.
- Change grease every 20,000 hours or every 3~5 years.

Table D-20 Recommended Grease for F4CF-D Series

Name of recommended	Supplier
Multemp FZ No.00	Kyodo Yushi Co., Ltd.

Ambient Temperature: -10°C~40°C

Table D-21

Frame size	Grease(g)			Position of grease filler port A(mm)
	Vertical ①	Vertical ②	Horizontal	
D15	55	40	50	20
D25	100	45	95	26
D30	220	85	200	29
D35	190	150	160	34
D45	320	260	270	39

Fig. D-17

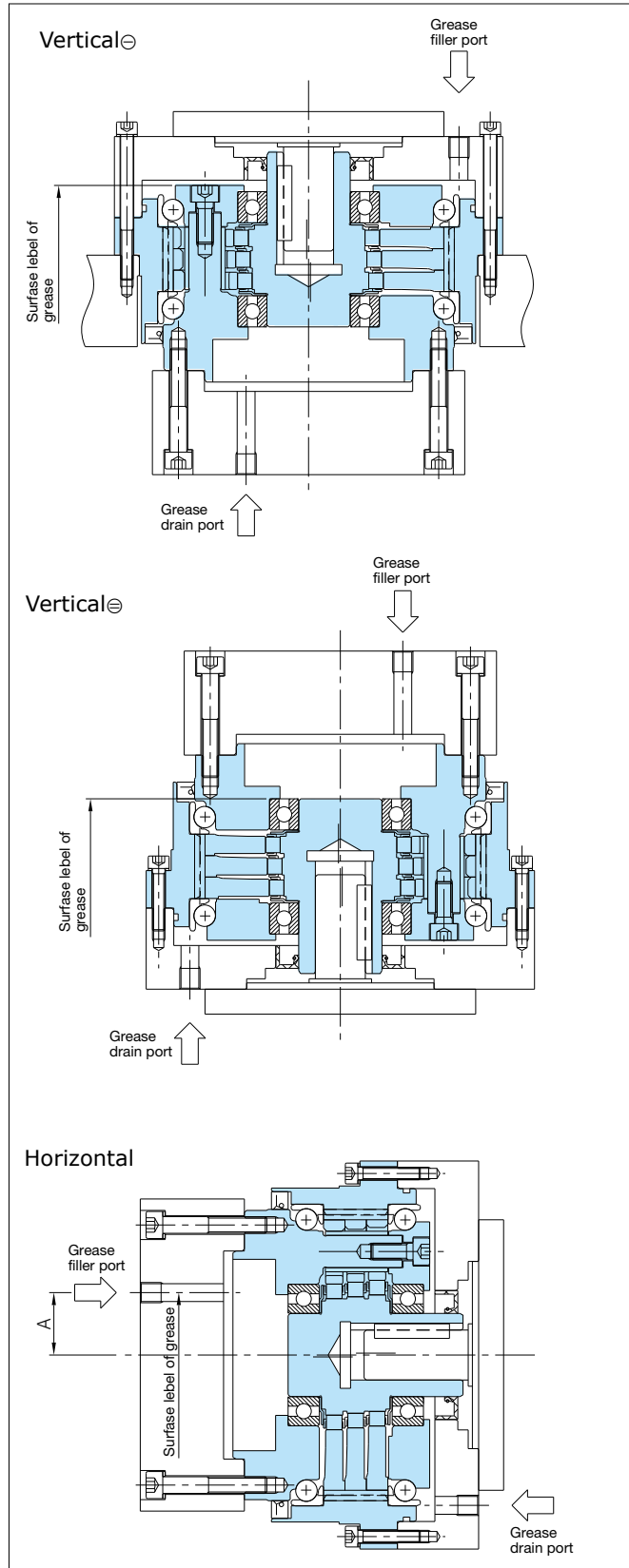



## F4CF-D30

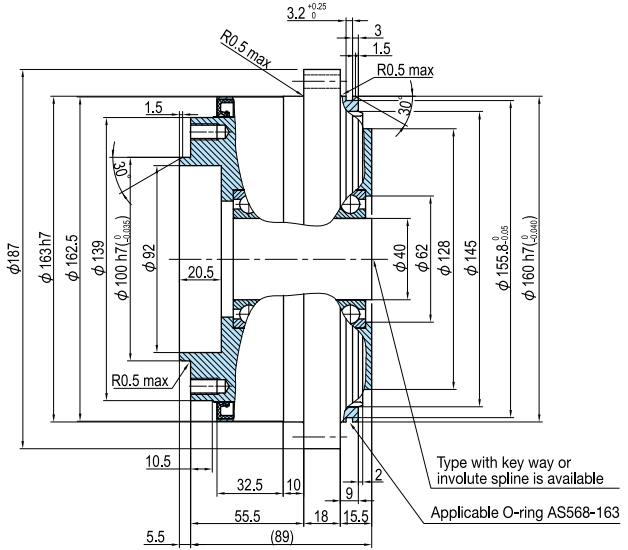
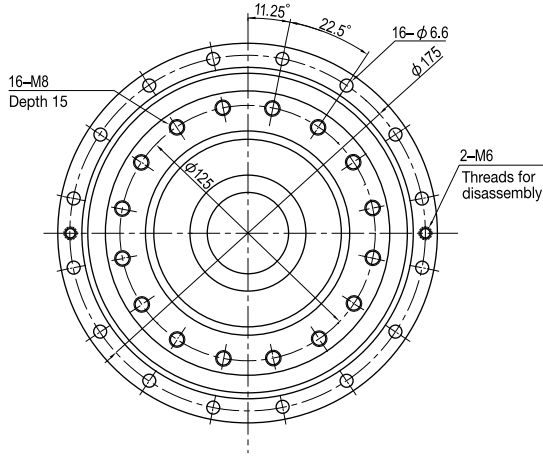

	Maximum diameter of hollow of high-speed shaft
Key method	φ27 (Key 8×7)
Spline method	φ30 (Involute spline 40×30×1.25)

Note: Consult us for the specification of high-speed shaft.

Mass 11kg

## F4CF-D35

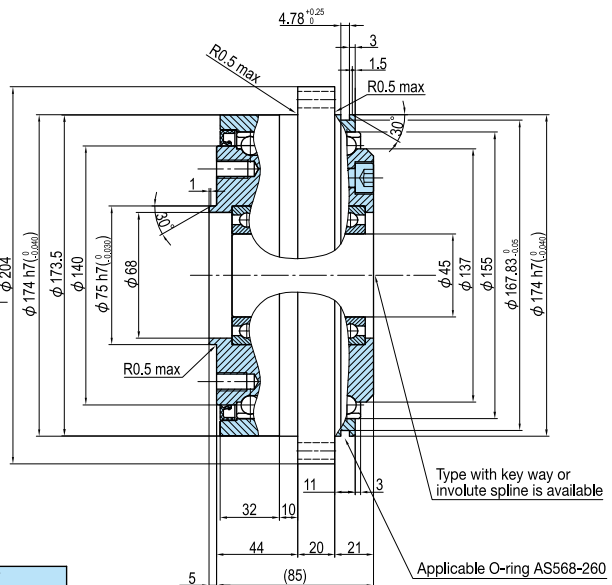
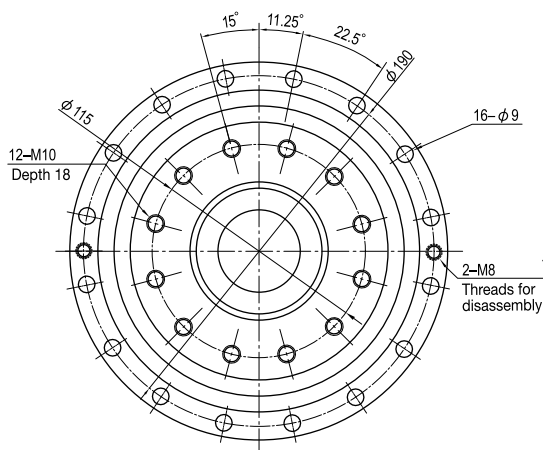

	Maximum diameter of hollow of high-speed shaft
Key method	φ32 (Key 10×8)
Spline method	φ35 (Involute spline 45×25×1.667)

Note: Consult us for the specification of high-speed shaft.

Mass 15kg



# MEMO

# MEMO

# Warranty

The scope of our warranty for our products is limited to the range of our manufacture.

Warranty (period and contents)

Warranty Period	The warranty period for the Products shall be 18 months after the commencement of delivery or 18 months after the shipment of the Products from the seller's works or 12 months from the Products coming into operation, whichever comes first.
Warranty Condition	<p>In the event that any problem or damage to the Product arises during the "Warranty Period" from defects in the Product whenever the Product is properly installed and combined with the Buyer,s equipment or machines, maintained as specified in the maintenance manual, and properly operated under the conditions described in the catalog or as otherwise agree upon in writing between the Seller and the Buyer or its customers ; the Seller will provide, at its sole discretion, appropriate repair or replacement of the Product without charge at a designated facility, except as stipulated in the "Warranty Exclusions" as described below.</p> <p>However, if the Product is installed or integrated into the Buyer,s equipment or machines, the Seller shall not reimburse the cost of : removal or re-installation of the Product or other incidental costs related thereto, any lost opportunity, any profit loss or other incidental or consequential losses or damages incurred by the Buyer or its customers.</p>
Warranty Exclusions	<p>Notwithstanding the above warranty, the warranty as set forth herein shall not apply to any problem or damage to the Product that is caused by :</p> <ol style="list-style-type: none"> <li>1. installation, connection, combination or integration of the Product in or to the other equipment or machine that is rendered by any person or entity other than the Seller ;</li> <li>2. insufficient maintenance or improper operation by the Buyer or its customers, such that the Product is not maintained in accordance with the maintenance manual provided or designated by the Seller ;</li> <li>3. improper use or operation of the Product by the Buyer or its customers that is not informed to the Seller, including, without limitation, the Buyer,s or its customers, operation of the Product not in conformity with the specifications, or use of lubricating oil in the Product that is not recommended by the Seller ;</li> <li>4. any problem or damage on any equipment or machine to which the Product is installed, connected or combined or on any specifications particular to the Buyer or its customers ;</li> <li>5. any changes, modifications, improvements or alterations to the Product or those functions that are rendered on the Product by any person or entity other than the Seller ;</li> <li>6. any parts in the Product that are supplied or designated by the Buyer or its customers ;</li> <li>7. earthquake, fire, flood, sea-breeze, gas, thunder, acts of God or any other reasons beyond the control of the Seller ;</li> <li>8. normal wear and tear, or deterioration of the Product,s parts, such as bearings, oil-seals ;</li> <li>9. any other troubles, problems or damage to the Product that are not attributable to the Seller.</li> </ol>

# Worldwide Sumitomo Network

## U.S.A.

Sumitomo Machinery Corporation of America (SMA)  
4200 Holland Blvd.  
Chesapeake, VA 23323,  
U.S.A.  
Tel: (1) 757-485-3355  
Fax: (1) 757-487-3193

## Canada

SM-Cyclo of Canada, Ltd. (SMC)  
1045 South Service Road,  
West Oakville Ontario,  
Canada L6L 6K3  
Tel: (1) 905-469-1050  
Fax: (1) 905-469-1055

## Mexico

SM-Cyclo De Mexico, S.A. de C.V. (SMME)  
Calle "C" No. 506A Parque Industrial  
Almacentro Apodaca, N. L., Mexico 66600  
Tel: (52) 81-8369-3697  
Fax: (52) 81-8369-3699

## Brazil

SM-Cyclo Redutores Do Brasil, Ltda. (SMBR)  
Av. Fagundes Filho, 191 Metro Sao Judas  
Edificio Houston-Sala H123 Sao Paulo-SP  
Brazil 04304-010  
Tel: (55) 11-5585-3600  
Fax: (55) 11-5585-9990

## Chile

SM-Cyclo De Chile, Ltda. (SMCH)  
San Pablo Ave, 3507 Quinta Normal,  
Santiago, Chile  
Tel: (56) 2-786-6963  
Fax: (56) 2-786-6964

## Argentina

SM-Cyclo De Argentina S.A. (SMAR)  
Montes de Oca #6719, (B1606BMG) Munro,  
Buenos Aires, Argentina  
Tel: (54) 11-4765-5288  
Fax: (54) 11-4765-5517

## United Kingdom

SM-Cyclo U.K. Ltd. (SMUK)  
29 Bergen Way,  
Sutton Fields Industrial Estate  
Kingston upon Hull,  
East Yorkshire HU7 0YQ  
United Kingdom  
Tel: (44) 1482-790340  
Fax: (44) 1482-790321

## France

SM-Cyclo France E.U.R.L. (SMFR)  
65/75 Avenue Jean Mermoz  
F-93126 La Courneuve,  
France  
Tel: (33) 149-929494  
Fax: (33) 149-929490

## Italy

SM-Cyclo Italy Srl (SMIT)  
Via dell' Artigianato 231-20010  
Cornaredo (MI),  
Italy  
Tel: (39) 02-9356-2121  
Fax: (39) 02-9356-9893

## Netherlands

SM-Cyclo Benelux BV (SMBE)  
Den Engelsman 16D NL-6026 RB  
Maarheeze,  
Netherlands  
Tel: (31) 495599777  
Fax: (31) 495593177

## Sweden

SM-Cyclo Scandinavia AB (SMCS)  
Ridbanegatan 4213 77 Malmö,  
Sweden Postal Address: box  
9178, SE-200 39 Malmö  
Tel: (46) 40220030  
Fax: (46) 40220035

## Spain

SM-Cyclo Iberia, S.L. (SMIB)  
C/Landabarri N 4 Escalera 1, 2 izqda Leioa  
48940 Vizcaya Spain  
Tel: (34) 944-805389  
Fax: (34) 944-801550

## Germany

Sumitomo (SHI) Cyclo Drive Germany, GmbH (SCG)  
Cyclostraße 92  
85229 Markt Indersdorf  
Germany  
Tel: (49) 8136-66-0  
Fax: (49) 8136-5771

## Austria

SCG Branch Austria Office  
Gruentalerstraße 30A A4028 Linz,  
Austria  
Tel: (43) 732-330958  
Fax: (43) 732-331978

## China

Sumitomo (SHI) Cyclo Drive China, Ltd. (SCT)  
Room 2606, Raffles City, No. 268,  
Middle Xizang Road,  
Shanghai 200001,  
China  
Tel: (86) 21-6340-4000  
Fax: (86) 21-6340-3673

## Hong Kong

SM-Cyclo of Hong Kong Co., Ltd. (SMHK)  
Unit 1802, 18/F, Park Building,  
476 Castle Peak Road, Kowloon,  
Hong Kong  
Tel: (852) 2460-1881  
Fax: (852) 2460-1882

## Singapore

Sumitomo (SHI) Cyclo Drive Asia Pacific Pte. Ltd. (SCA)  
No.36 Tuas South Street 3,  
Singapore 638031  
Tel: (65) 6863-2238  
Fax: (65) 6863-4238

## Malaysia

SM-Cyclo (Malaysia) Sdn. Bhd. (SMMA)  
No.2, Jalan BP 4/1,  
Bandar Bukit Puchong, 47100 Puchong,  
Selangor Darul Ehsan,  
Malaysia  
Tel: (60) 3-8061-2909  
Fax: (60) 3-8061-3909

## Thailand

SM-Cyclo (Thailand) Co., Ltd. (SMTH)  
195, Empire Tower,  
21st Floor Unit 2103-4  
South Sathorn Road,  
Yannawa Sathorn Bangkok 10120,  
Thailand  
Tel: (66) 2-670-0998  
Fax: (66) 2-670-0999

## Vietnam

Sumitomo (SHI) Cyclo-Drive Asia Pacific Pte. Ltd.  
Representative Office in Ho Chi Minh  
Floor 4th, 99 Nguyen Thi Minh Khai Street  
World Ben Thanh, District 1, HCM,  
Vietnam  
Tel: (84) 8-925-6504  
Fax: (84) 8-925-6505

## Australia

SM-Cyclo (Australia) Pty., Ltd. (SMAU)  
9 Holbeche Rd,  
Arndell Park, NSW, 2148,  
Australia  
Postal: PO Box 319 Doonside NSW, 2767  
Tel: (61) 2-8811-6555  
Fax: (61) 2-8811-6500  
National Telephone Number: 1-3000 DRIVE

## Philippines

Sumitomo (SHI) Cyclo Drive Asia Pacific Pte. Ltd.  
Representative Office  
Unit 23E Burgundy Corporate Tower  
252 Sen. Gil Puyat Ave. Makati City,  
Philippines  
Tel: (63) 2-6800-6500  
Fax: (63) 2-6800-6555

## India

Sumi-Cyclo Drive India Private, Ltd. (SMIN)  
Survey No. 130, Hissa No. 02, Jeevan Nagar  
Next to T. V. S. Logistics,  
Off Mumbai Bangalore By Pass,  
Tathawade, Pune 411 033,  
India  
Tel: (91) 20-6674-2900  
Fax: (91) 20-6674-2901

## Taiwan

Tatung SM-Cyclo Co., Ltd. (TSC)  
22 Chungshan N. Road  
3rd., Sec. Taipei, Taiwan 104, R.O.C.  
Tel: (886) 2-2595-7275  
Fax: (886) 2-2595-5594

## Korea

Sumitomo (SHI) Cyclo Drive Korea Ltd. (SCK)  
Royal Bldg. 9F Rm. 913,  
5 Danju-dong, Jongro-Gu,  
Seoul, Korea 110-721  
Tel: (82) 2-730-0151  
Fax: (82) 2-730-0156

## Japan

Sumitomo Heavy Industries, Ltd.  
ThinkPark Tower, 1-1, Osaki 2-Chome  
Shinagawa-ku, Tokyo 141-6025,  
Japan  
Tel: (81) 3-6737-2511  
Fax: (81) 3-6866-5160