

Sumitomo Drive Technologies
Always on the Move

PARAMAX[®] 9000 Series
The Aerator Drives



No. G2501E-2

Features

1. Stronger output shaft support

- Paramax 9000 drop bearing housing extend bearing span makes sure stronger output shaft support.

2. Drive Package

- Motor (IEC,NEMA)
- Coupling
- Anti corrosion paint

Drop Bearing Housing

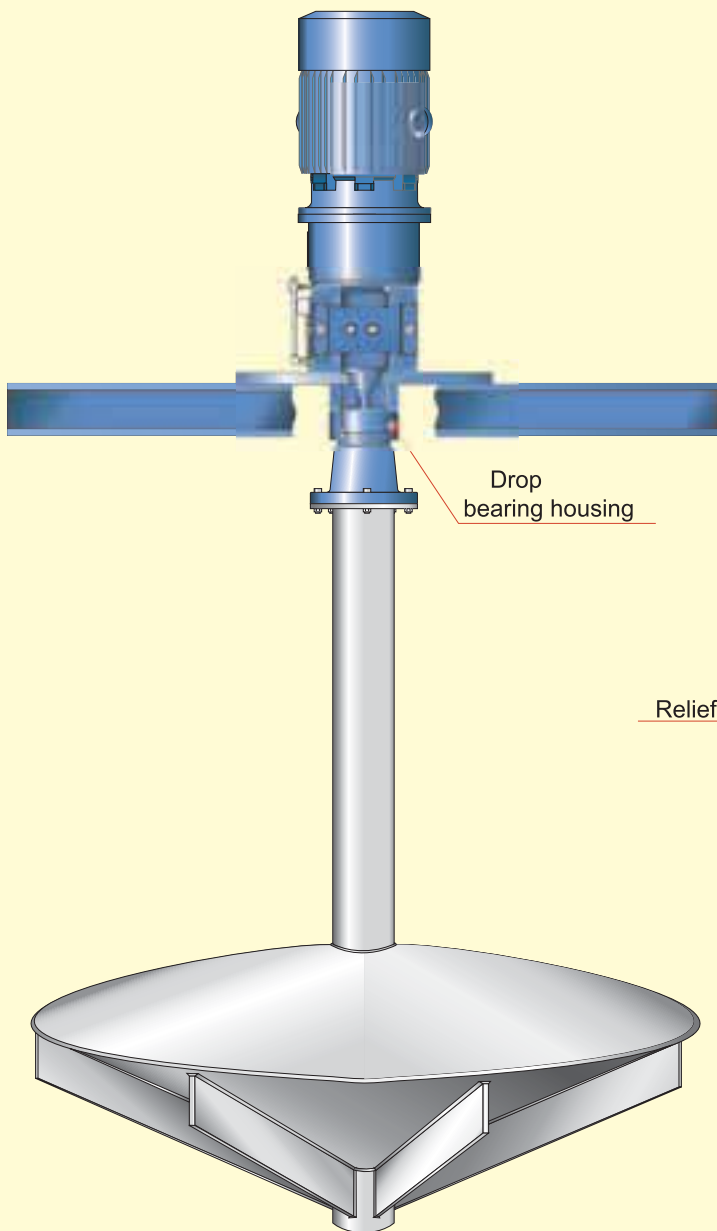

Drive Package

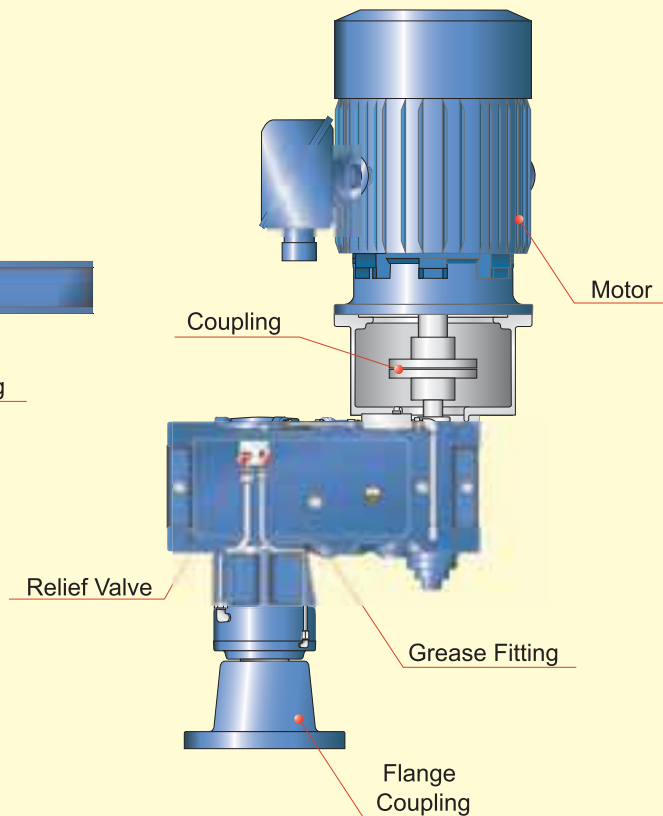

3. High Reliability for 24 hours continuous operation

Dry well on output shaft prevents oil leaking
25 degree pressure angle tooth form produces stronger gearing

Gears are heat treated and finished to the highest standard accuracy.

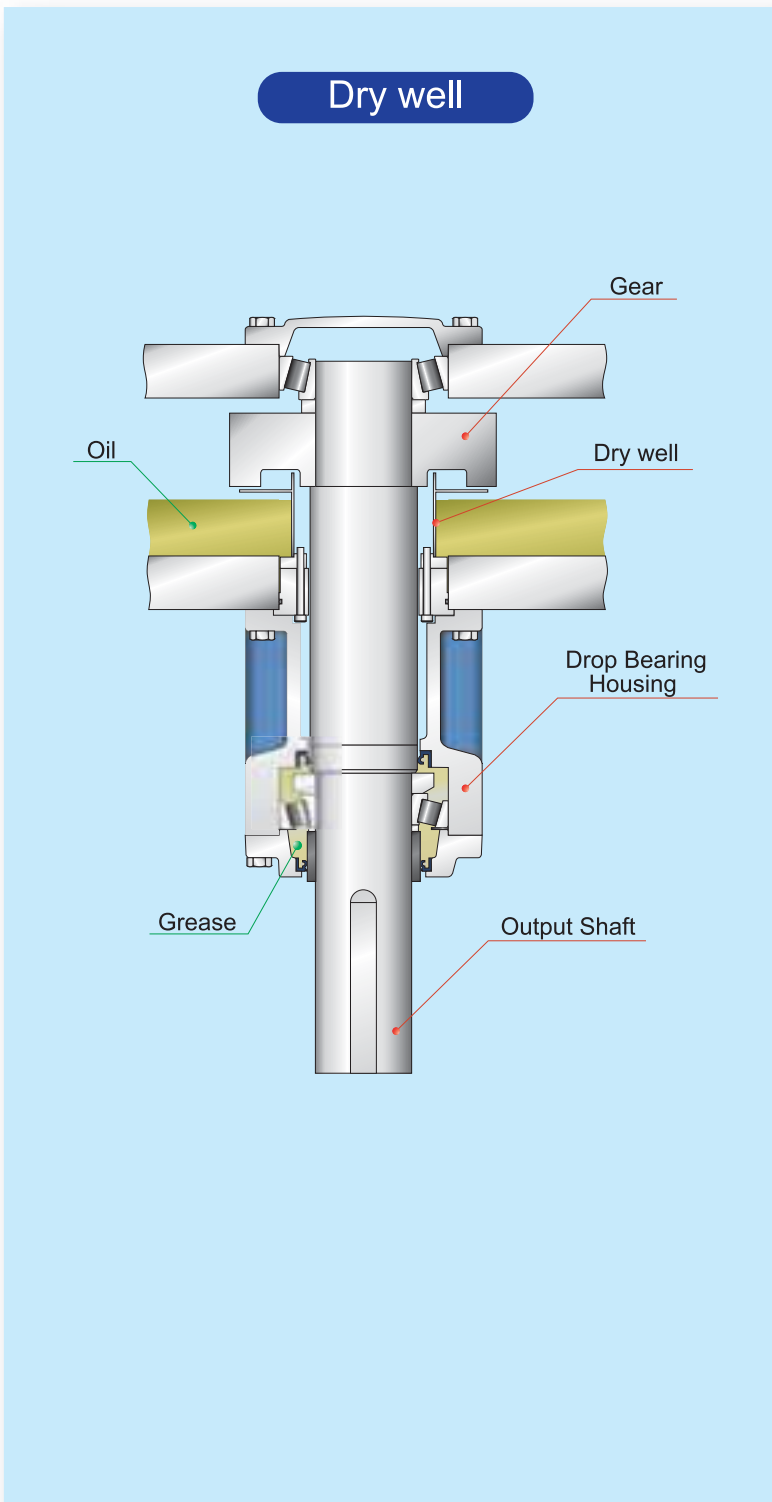

Nomenclature/Standard Specifications/Painting Specifications

Nomenclature

PV	A	9035	P	3	D	—	R	M	L	—	45
----	---	------	---	---	---	---	---	---	---	---	----

Series	Housing	Size	Torque kNm	Shaft Position	Number of Gear Stages	Drop Bearing Housing	Shaft Arrangement	Motor	Nominal Ratio
PV Paramax Vertical Mount	A Monoblock (9015 ▶ 9050)	9015	2.6	P 	2	D With Drop Bearing Housing	RL	M With Motor (Drive Unit)	6.3 ▼ 90
		9025	4.2					J With Motor Adapter	
		9030	6.4		(Blank)				
		9035	8.5						
		9040	10.1	3	Without Motor (Reducer)				
		9045	13.1						
		9050	15.3						

Standard Specifications

Item		Standard Specification
Reducer	Mounting	Vertical Shaft
	Input Speed	400 ▶ 1800 r/min
	Lubrication	All size use shaft connected pump lubrication which doesn't need electric power.
	Gear	All gears are manufactured from vacuum degassed alloy steel and are finished to high accuracy.
Motor	with brake	5.5kW× 4P ▶ 37kW×4P 3Phase, built-in brake
	Without Brake	5.5kW× 4P ▶ 55kW× 4P 3Phase
Ambient Conditions	Installation location	Indoor (Consult us for outdoor use)
	Ambient temperature	-10°C ▶ 40°C (Consult us for other temperature)
	Ambient humidity	under 85%
	Elevation	under 1,000 meters
	Atmosphere	Well ventilated location, free of corrosive gases, explosive gases, vapors and dust.

Painting Specifications

Painting Area	Surface Conditioning	Installation Location	Paint Specification				
			Finish Coat	Type	Coating	Thickness(μ)	Type of Coating
Outside Painting	Cast Iron Class 1	Indoor	Modified epoxy	Under	2	40 ▶ 80	Modified alkyd resin
				Finish	1	15 ▶ 30	Vinyl modified epoxy resin
		Seaside, outdoor humid atmosphere	Chloride rubber	Under	2	40 ▶ 80	Lead rust preventive paint
				Second	1	20 ▶ 40	Phenol M.I.O paint
	Steel Plate Class 2	In-and-outdoor of acid treating plant and chemical plant	Phenol	Under	2	40 ▶ 80	Lead rust preventive paint
				Finish	2	30 ▶ 60	Phenol resin enamel
		Indoor anti-corrosion area, Chemical plant	Epoxy	Under	2	40 ▶ 80	Special permeability epoxy aluminum paint
				Finish	3	120 ▶ 240	Polyamide epoxy
Inside Painting	Cast Iron Class 1 Steel Plate Class 3	Standard painting			1	20 ▶ 40	Modified alkyd resin

Lubricant

Lubricant

Output speed		Ambient temperature		
		- 10°C to +15°C	0°C to +30°C	+10°C to +50°C
Over 100 r/min	ISO* AGMA	VG68 2EP	VG150 4EP	VG220 5EP
Under 100 r/min	ISO* AGMA	VG100 3EP	VG220 5EP	VG320 6EP

Paramax Drive is shipped without lubricant oil.

Supply oil within the range shown on the oil gauge before operation.

The table on the right shows appropriate viscosity of oil based on ISO and AGMA for respective ambient temperatures and output speed.

When the ambient temperature is lower than -10 degreeC or higher than +50 degreeC, a heating or cooling unit is necessary, in general.

* Kinetic Viscosity (cSt) at ISO 40°C

Recommended Lubricants

Brand		BP	CASTROL			CHEVRON TEXACO		EXXON MOBIL		SHELL	TOTAL
Gear Oil	ISO VG68 AGMA 2EP	ENERGOL GR-XP-68	ALPHA SP68	OPTIGEAR BM68	TRIBOL 1100/68	GEAR COMPOUNDS EP68	MEROPA WM68	SPARTAN EP68	MOBIL- GEAR 626	OMALA 68	CARTER EP68
	ISO VG100 AGMA 3EP	ENERGOL GR-XP-100	ALPHA SP100	OPTIGEAR BM100	TRIBOL 1100/100	GEAR COMPOUNDS EP100	MEROPA WM100	SPARTAN EP100	MOBIL- GEAR 627	OMALA 100	CARTER EP100
	ISO VG150 AGMA 4EP	ENERGOL GR-XP-150	ALPHA SP150	OPTIGEAR BM150	TRIBOL 1100/150	GEAR COMPOUNDS EP150	MEROPA WM150	SPARTAN EP150	MOBIL- GEAR 629	OMALA 150	CARTER EP150
	ISO VG220 AGMA 5EP	ENERGOL GR-XP-220	ALPHA SP220	OPTIGEAR BM220	TRIBOL 1100/220	GEAR COMPOUNDS EP220	MEROPA WM220	SPARTAN EP220	MOBIL- GEAR 630	OMALA 220	CARTER EP220
	ISO VG320 AGMA 6EP	ENERGOL GR-XP-320	ALPHA SP320	OPTIGEAR BM320	TRIBOL 1100/320	GEAR COMPOUNDS EP320	MEROPA WM320	SPARTAN EP320	MOBIL- GEAR 632	OMALA 320	CARTER EP320
Bearing grease		ENER- GREASE LS EP2	SPHEEROL AP3	Olista Long- time 3EP	TRIBOL 3020/ 1000-2	DURALITH GREASE 68	MULTI- FAK EP2	BEACON EP2	MOBILUX EP2	ALVANIA EP2	MULTIS EP2

Application Data Sheet

Application Data Sheet

Enter the required specifications below when inquiring about PARAMAX 9000 aerator drive.

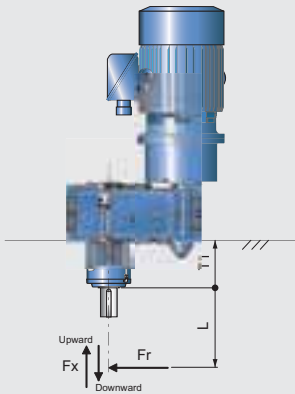
Installation environment	<input type="checkbox"/> Indoor <input type="checkbox"/> Outdoor <input type="checkbox"/> Seaside <input type="checkbox"/> Chemical plant area																			
Special environment	<input type="checkbox"/> Tropical treatment <input type="checkbox"/> ()																			
Ambient temperature	min _____ °C max _____ °C																			
Motor	_____ kW P V Hz <input type="checkbox"/> Sumitomo prepare <input type="checkbox"/> Supplied by customer <input type="checkbox"/> Customer prepare Special specifications of motor _____ Based standard _____																			
Speed change	<table style="width:100%; border:none;"> <tr> <td style="width:30%;"></td> <td style="text-align:center;">Input speed</td> <td style="text-align:center;">Output speed</td> </tr> <tr> <td><input type="checkbox"/> Constant speed</td> <td style="text-align:center;">_____ r/min</td> <td style="text-align:center;">_____ r/min</td> </tr> <tr> <td rowspan="3"><input type="checkbox"/> Inverter</td> <td style="text-align:center;"><input type="checkbox"/> Diminish torque</td> <td style="text-align:center;">_____ to _____ r/min</td> </tr> <tr> <td style="text-align:center;"><input type="checkbox"/> Constant torque</td> <td style="text-align:center;">_____ to _____ r/min</td> </tr> <tr> <td style="text-align:center;"><input type="checkbox"/> Constant power</td> <td style="text-align:center;">_____ to _____ r/min</td> </tr> <tr> <td><input type="checkbox"/> Pole change</td> <td style="text-align:center;"><input type="checkbox"/> Constant torque</td> <td></td> </tr> <tr> <td></td> <td style="text-align:center;"><input type="checkbox"/> Constant power</td> <td></td> </tr> </table>		Input speed	Output speed	<input type="checkbox"/> Constant speed	_____ r/min	_____ r/min	<input type="checkbox"/> Inverter	<input type="checkbox"/> Diminish torque	_____ to _____ r/min	<input type="checkbox"/> Constant torque	_____ to _____ r/min	<input type="checkbox"/> Constant power	_____ to _____ r/min	<input type="checkbox"/> Pole change	<input type="checkbox"/> Constant torque			<input type="checkbox"/> Constant power	
	Input speed	Output speed																		
<input type="checkbox"/> Constant speed	_____ r/min	_____ r/min																		
<input type="checkbox"/> Inverter	<input type="checkbox"/> Diminish torque	_____ to _____ r/min																		
	<input type="checkbox"/> Constant torque	_____ to _____ r/min																		
	<input type="checkbox"/> Constant power	_____ to _____ r/min																		
<input type="checkbox"/> Pole change	<input type="checkbox"/> Constant torque																			
	<input type="checkbox"/> Constant power																			
High speed shaft connection	<input type="checkbox"/> Motor built-in <input type="checkbox"/> Pulley & belt _____ to _____ r/min Radial load _____ N																			
Low speed shaft connection	<input type="checkbox"/> Rigid coupling <input type="checkbox"/> () Radial load F_r _____ From mounting area(T1+L) _____ mm Axial load F_x _____ N Direction <input type="checkbox"/> Upward <input type="checkbox"/> Downward <input type="checkbox"/> Both direction																			
																				
	<input type="checkbox"/> Sumitomo prepare <input type="checkbox"/> Supplied by customer <input type="checkbox"/> Customer prepare																			
Installation Location	<input type="checkbox"/> indoor <input type="checkbox"/> Seaside, outdoor humid atmosphere <input type="checkbox"/> In-and-outdoor of acid treating plant and chemical plant <input type="checkbox"/> Indoor anti-corrosion area, Chemical plant <input type="checkbox"/> Customer's specification _____																			
Option	<input type="checkbox"/> Air breather <input type="checkbox"/> Drain valve <input type="checkbox"/> Pipe type oil gauge <input type="checkbox"/> ()																			

Selection

● Selection Flow

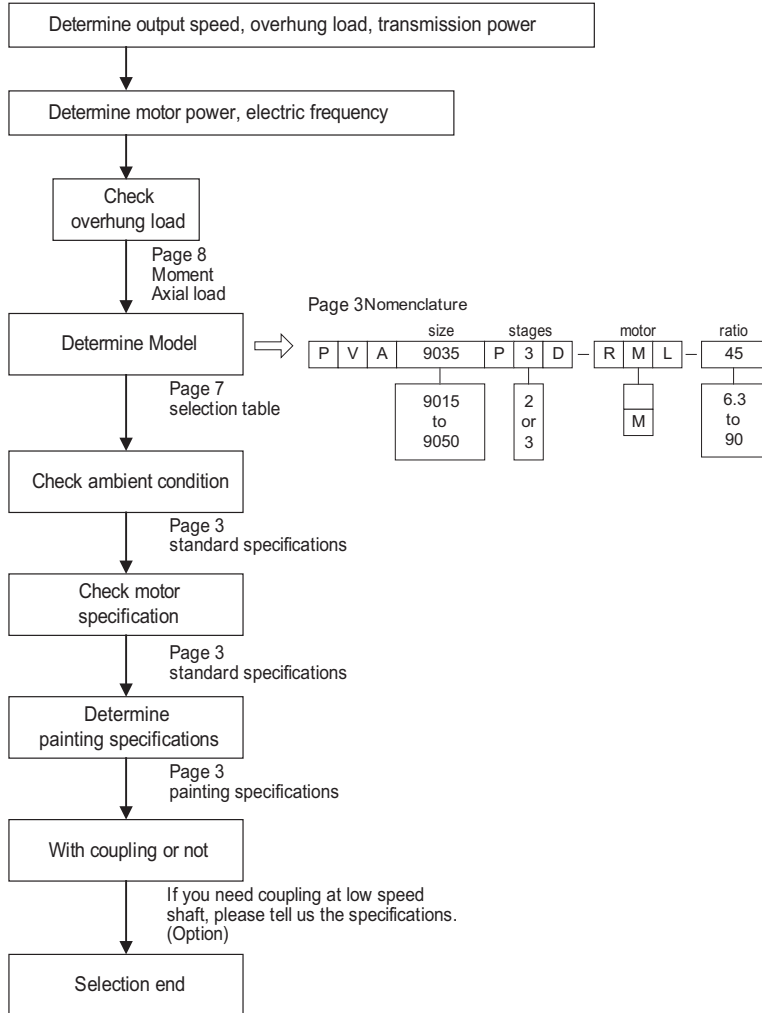

● Selection Example

○ Conditions ■ Selected item

- Output speed : 40r/min
- Transmission power : 12kW
- Motor power : 15kW
- Electric frequency : 200V60Hz

- Overhung load
- Radial load : Fr : 6kN
- Distance to load point : L : 1.5m
- Axial load : Fx : 10kN
- Reducer size : 9035 or 9040

- Reducer size : 9035
- Stage : 3
- Ratio : 45
- Model : PVA9035P3D-RML-45

- Installation location : Indoor
- Ambient temperature : 20°C
- OK

- 15kW 4P 200V 60Hz
- Indoor, Without brake
- OK

- Installation location : Indoor
- Indoor standard coat : Modified epoxy

- With coupling
- Tell us specifications of coupling.

- PVA9035P3D-RML-45
Motor 15kW 200V 60Hz
Indoor, Without brake
With coupling

Selection Table

This selection table is a result when the service factor = 2.0

Input Speed	Shaft Position	Ambient Temperature
1800r/min	Parallel Shaft	40°C

Motor kW	Output Speed (r/min)																							
	286	254	225	200	180	161	144	129	113	100	90	80	72	64	57	51	45	40	36	32	29	25	23	20
	Nominal Reduction Ratio																							
	6.3	7.1	8	9	10	11.2	12.5	14	16	18	20	22.4	25	28	31.5	35.5	40	45	50	56	63	71	80	90
5.5kW	9015 9015 9015 9015 9015 9015 9015 9015 9015 9015 9015 9015 9015 9015 9015 9015 9015 9015 9030 9030 9030 9030 9035 9035																							
7.5kW	9015 9015 9015 9015 9015 9015 9015 9015 9015 9015 9015 9015 9015 9025 9025 9025 9025 9030 9030 9030 9030 9035 9035 9035 9035																							
11kW	9015 9015 9015 9015 9015 9015 9015 9015 9015 9015 9025 9025 9025 9025 9030 9030 9030 9030 9030 9030 9035 9035 9055 9045																							
15kW	9015 9015 9015 9015 9015 9015 9015 9015 9015 9025 9025 9025 9025 9030 9030 9030 9030 9035 9035 9040 9040 9045 9045																							
18.5kW	9015 9015 9015 9015 9015 9015 9015 9015 9025 9025 9025 9025 9030 9030 9030 9030 9035 9035 9040 9040 9045 9045 9050																							
22kW	9015 9015 9015 9015 9015 9025 9025 9025 9025 9030 9030 9030 9030 9035 9035 9040 9045 9045 9050 9050																							
30kW	9025 9025 9025 9025 9025 9025 9025 9030 9030 9030 9030 9035 9035 9040 9040 9045 9045 9050 9050																							
37kW	9030 9030 9030 9030 9030 9030 9030 9030 9035 9035 9035 9040 9040 9045 9045 9050 9050																							
45kW	9035 9035 9035 9035 9035 9035 9035 9035 9040 9040 9045 9045 9050 9050																							
55kW	9040 9040 9040 9040 9040 9040 9040 9040 9045 9045 9045 9050																							

Input Speed	Shaft Position	Ambient Temperature
1500r/min	Parallel Shaft	40°C

Motor kW	Output Speed (r/min)																							
	238	211	188	167	150	134	120	107	94	83	75	67	60	54	48	42	38	33	30	27	24	21	19	17
	Nominal Reduction Ratio																							
	6.3	7.1	8	9	10	11	13	14	16	18	20	22	25	28	32	36	40	45	50	56	63	71	80	90
5.5kW	9015 9015 9015 9015 9015 9015 9015 9015 9015 9015 9015 9015 9015 9015 9015 9015 9015 9015 9025 9030 9030 9030 9030 9035 9035																							
7.5kW	9015 9015 9015 9015 9015 9015 9015 9015 9015 9015 9015 9015 9015 9025 9025 9025 9025 9030 9030 9030 9030 9035 9035 9035																							
11kW	9015 9015 9015 9015 9015 9015 9015 9015 9015 9015 9025 9015 9025 9025 9025 9030 9030 9030 9030 9035 9035 9040 9040 9045 9045																							
15kW	9015 9015 9015 9015 9015 9015 9015 9015 9025 9025 9025 9025 9030 9030 9030 9030 9035 9035 9035 9040 9045 9045 9050																							
18.5kW	9015 9015 9015 9015 9015 9025 9025 9025 9025 9030 9030 9030 9030 9030 9035 9035 9040 9045 9045 9050 9050																							
22kW	9015 9015 9015 9025 9025 9025 9025 9030 9030 9030 9030 9030 9035 9035 9040 9045 9045 9045 9050																							
30kW	9025 9025 9025 9025 9025 9030 9030 9030 9030 9035 9035 9040 9040 9045 9045 9050 9050																							
37kW	9025 9030 9030 9030 9030 9030 9030 9035 9035 9040 9040 9045 9045 9050 9050																							
45kW	9040 9040 9035 9035 9035 9035 9035 9035 9040 9045 9045 9050 9050																							
55kW	9040 9040 9040 9040 9040 9040 9040 9045 9045 9050 9050																							
75kW	9050 9050																							

Selection Table

Allowable Moment / Axial Load

This selection table is a result when the Bearing B10 Life 50,000hrs

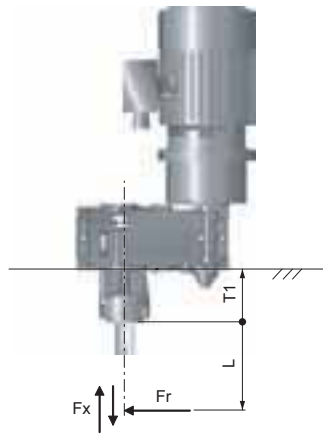

- F_r : Actual Radial Load
- F_x : Actual Axial Load
- L : Distance to Load Point
- M_B : Actual Moment = $F_r \times L$
- M_{BA} : Allowable Moment
- F_{XA} : Allowable Axial Load

Low Speed Shaft Speed 100r/min

F_{XA} (kN)	M_{BA} (kNm)																																			
	~1	1.5	2	2.5	3	3.5	4	4.5	5	5.5	6	6.5	7	7.5	8	8.5	9	9.5	10	10.5	11	11.5	12	12.5	13	13.5	14	14.5	15	15.5	16	16.5	17			
~2	9015		9025		9030																															
4	9015		9025		9030																															
6	9015		9025		9030																															
8	9015		9025		9030																															
10	9015		9025		9030																															
12	9015		9025		9030																															
14	9015		9025		9030																															
16	9015		9025		9030																															
18	9015		9025		9030																															
20	9015		9025		9030																															
22	9015		9025		9030																															
24	9015		9025		9030																															

Low Speed Shaft Speed 63r/min

F_{XA} (kN)	M_{BA} (kNm)																																			
	~1	1.5	2	2.5	3	3.5	4	4.5	5	5.5	6	6.5	7	7.5	8	8.5	9	9.5	10	10.5	11	11.5	12	12.5	13	13.5	14	14.5	15	15.5	16	16.5	17			
~2	9015		9025		9030																															
4	9015		9025		9030																															
6	9015		9025		9030																															
8	9015		9025		9030																															
10	9015		9025		9030																															
12	9015		9025		9030																															
14	9015		9025		9030																															
16	9015		9025		9030																															
18	9015		9025		9030																															
20	9015		9025		9030																															
22	9015		9025		9030																															
24	9015		9025		9030																															
26	9015		9025		9030																															
28	9015		9025		9030																															
30	9015		9025		9030																															

Low Speed Shaft Speed 40r/min

F_{XA} (kN)	M_{BA} (kNm)																																			
	~1	1.5	2	2.5	3	3.5	4	4.5	5	5.5	6	6.5	7	7.5	8	8.5	9	9.5	10	10.5	11	11.5	12	12.5	13	13.5	14	14.5	15	15.5	16	16.5	17			
~2	9015		9025		9030																															
4	9015		9025		9030																															
6	9015		9025		9030																															
8	9015		9025		9030																															
10	9015		9025		9030																															
12	9015		9025		9030																															
14	9015		9025		9030																															
16	9015		9025		9030																															
18	9015		9025		9030																															
20	9015		9025		9030																															
22	9015		9025		9030																															
24	9015		9025		9030																															
26	9015		9025		9030																															
28	9015		9025		9030																															
30	9015		9025		9030																															
32	9015		9025		9030																															
34	9015		9025		9030																															
36	9015		9025		9030																															

Dimensions Drive Unit Double Reduction 9015 ▶ 9050 P2

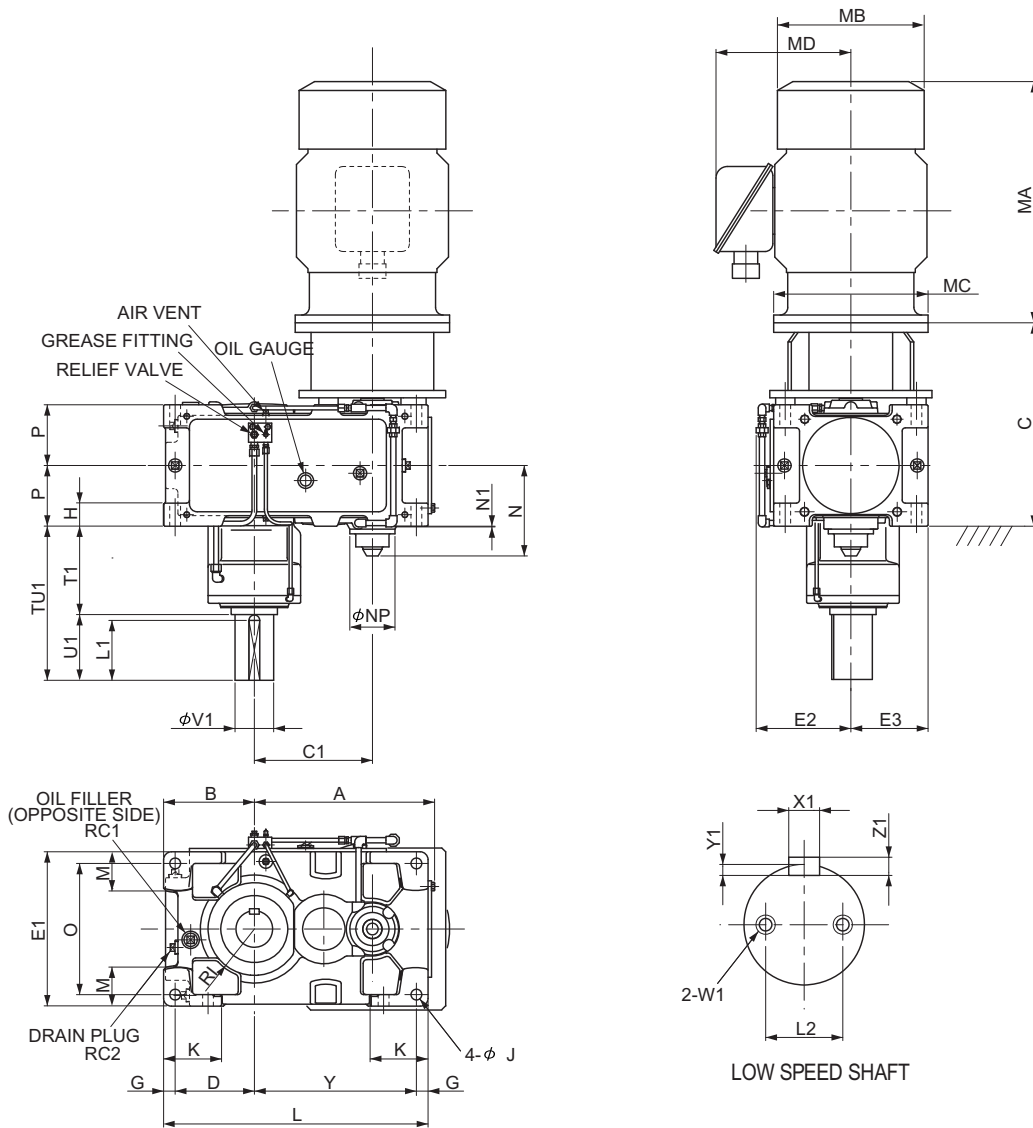

Units : mm

SIZE	A	B	C1	C	D	E1	E2	E3	G	H	RI	J	K	L	M	N	N1	NP	O	P	Y
9015	295	160	194		140	270	195	135	20	35	80	15	95	440	70	186	14	100	230	102.5	260
9025	346	175	227		155	310	215	155	20	40	87.5	19	110	505	75	198.5	12	100	270	117.5	310
9030	406	200	264		175	320	220	160	25	50	105	24	120	590	85	211	9	100	270	132.5	365
9035	437	219	295	See below	194	370	245	185	25	50	120	24	120	640	100	211	9	100	320	132.5	396
9040	467	235	306		205	400	260	200	30	60	120	28	150	685	100	237.5	2	117	340	157.5	420
9045	506	256	345		226	440	266	220	30	60	140	28	150	745	120	237.5	2	117	380	157.5	459
9050	537	255	358		225	420	270	210	30	60	140	28	150	775	110	257.5	7	117	360	172.5	490

SIZE	RC1	RC2	TU1	T1	U1	V1	W1/Depth	X1	Y1	Z1	L1	L2	Mass of Reducer (kg)	Oil Qty (L)
9015	3/4"	3/4"	350	240	110	60m6	M10/20	18	7	11	95	42	125	5
9025	3/4"	3/4"	384	244	140	70m6	M12/25	20	7.5	12	125	46	170	7
9030	3/4"	3/4"	396	226	170	85m6	M12/25	22	9	14	150	55	235	9
9035	3/4"	3/4"	406.5	236.5	170	100m6	M16/35	28	10	16	150	60	255	12
9040	1"	1"	399	229	170	100m6	M16/35	28	10	16	155	60	345	18
9045	1"	1"	439	229	210	105m6	M16/35	28	10	16	190	60	405	22
9050	1"	1"	423.5	214.5	209	110m6	M16/35	28	10	16	190	75	485	22

Motor kW	Motor						C							Mass of Motor Mounting Flange (kg)	Mass of Motor (kg)			
	Without Brake			With Brake			MD	9015	9025	9030	9035	9040	9045		9050	Without Brake	With Brake	
MA	MB	MC	MA	MB	MC													
5.5	382	212	315	454	212	315	144	397.5							8	43	54	
7.5	415	251	315	510	251	315	185	397.5	427.5							8	57	77
11	480	251	350	575	251	350	188	427.5	457.5	515.5					11	76	96	
15	545	324	350	700	324	350	232	427.5	457.5	515.5	515.5				11	131	175	
18.5	625	394	400	835	394	400	297	427.5	457.5	515.5	515.5	555.5	555.5	17	213	258		
22	625	394	400	835	394	400	297	427.5	457.5	515.5	515.5	555.5	555.5	17	213	258		
30	625	394	400	835	394	400	297	457.5	515.5	515.5	555.5	555.5	589.5	17	224	280		
37	715.5	394	450	930.5	394	450	297	487.5	545.5	545.5	585.5	585.5	619.5	15	259	320		
45	715.5	394	450	930.5	394	450	297	545.5	585.5	585.5	619.5	15	259	320				
55	769.5	484	550	-	-	-	412	585.5	585.5	619.5	29	276	-					
75	799	490	545	-	-	-	485	619.5	619.5	31	490	-						

Dimensions Drive Unit Triple Reduction 9015 ▶ 9050 P3

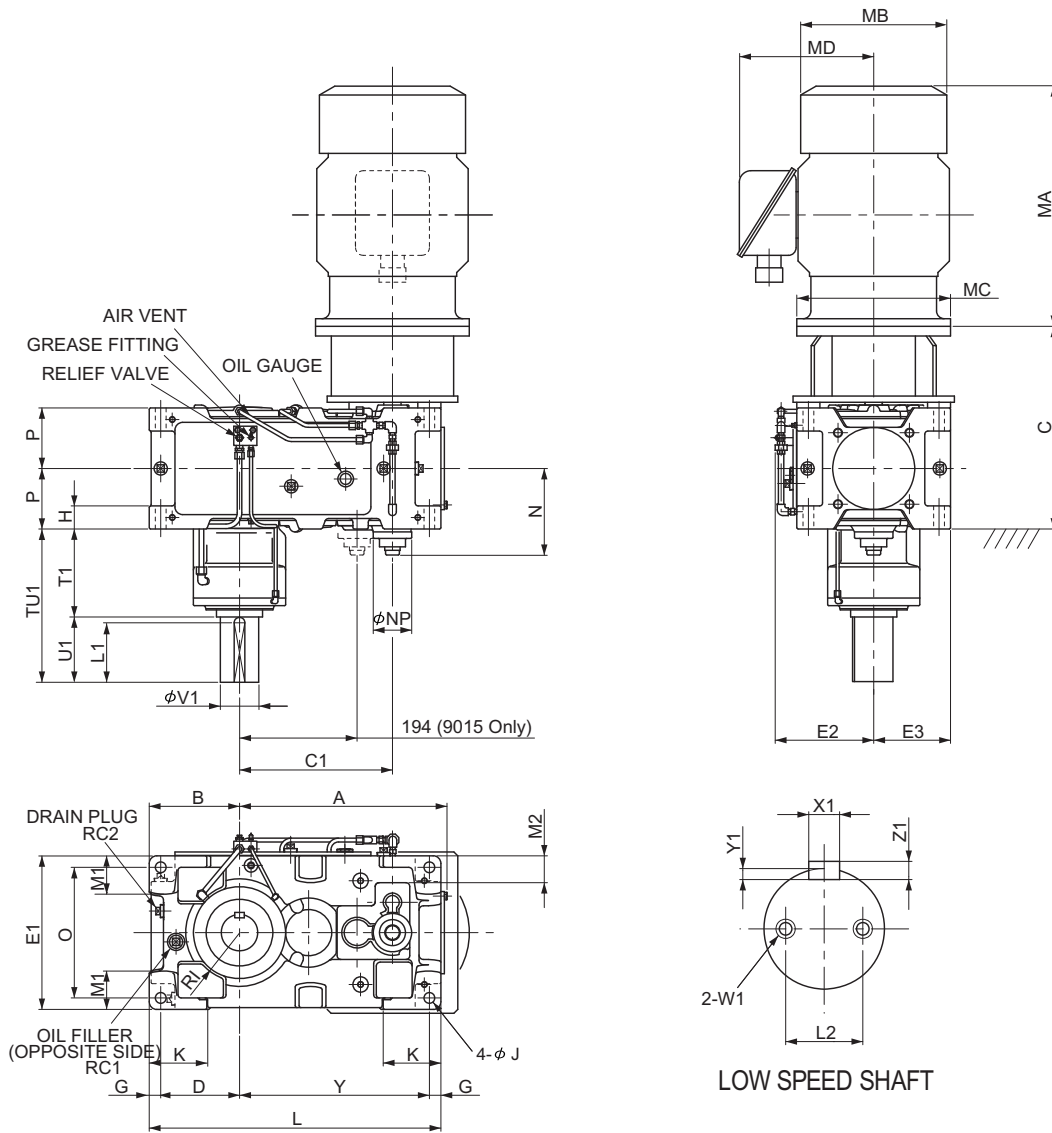

Units : mm

SIZE	A	B	C1	C	D	E1	E2	E3	G	H	RI	J	K	L	M1	M2	N	NP	O	P	Y
9015	338	160	257		140	270	195	135	20	35	80	15	95	485	70	80	186	100	230	102.5	305
9025	408	175	306		155	310	215	155	20	40	87.5	19	110	570	75	90	198.5	100	270	117.5	375
9030	453	200	343		175	320	220	160	25	50	105	24	120	640	85	50	211	100	270	132.5	415
9035	484	219	374	See Below	194	370	245	185	25	50	120	24	120	690	100	75	211	100	320	132.5	446
9040	540	235	398		205	400	260	200	30	60	120	28	150	759	100	70	228.5	100	340	157.5	494
9045	577	256	437		226	440	277	220	30	60	140	28	150	819	120	90	228.5	100	380	157.5	533
9050	609	255	467		225	420	270	210	30	60	140	28	150	848	110	83	248.5	100	360	172.5	563

SIZE	RC1	RC2	TU1	T1	U1	V1	W1/Depth	X1	Y1	Z1	L1	L2	Mass of Reducer (kg)	Oil Qty (L)
9015	3/4"	3/4"	350	240	110	60m6	M10/20	18	7	11	95	42	125	6
9025	3/4"	3/4"	384	244	140	70m6	M12/25	20	7.5	12	125	46	175	8
9030	3/4"	3/4"	396	226	170	85m6	M12/25	22	9	14	150	55	235	10
9035	3/4"	3/4"	406.5	236.5	170	100m6	M16/35	28	10	16	150	60	260	14
9040	1"	1"	399	229	170	100m6	M16/35	28	10	16	155	60	340	18
9045	1"	1"	439	229	210	105m6	M16/35	28	10	16	190	60	410	22
9050	1"	1"	423.5	214.5	209	110m6	M16/35	28	10	16	190	75	490	25

Motor kW	Motor						MD	C						Mass of Motor Mounting Flange (kg)	Mass of Motor (kg)	
	Without Brake			With Brake				9015	9025	9030	9035	9040	9045		9050	Without Brake
	MA	MB	MC	MA	MB	MC										
5.5	382	212	315	454	212	315	144	376.5	405.5	457.5	457.5	497.5	497.5	8	43	54
7.5	415	251	315	510	251	315	185	376.5	405.5	457.5	457.5	497.5	497.5	8	57	77
11	480	251	350	575	251	350	188	406.5	435.5	487.5	487.5	527.5	527.5	11	76	98
15	545	324	350	700	324	350	232	406.5	435.5	487.5	487.5	527.5	527.5	11	131	175
18.5	625	394	400	835	394	400	297		435.5	487.5	487.5	527.5	527.5	17	213	258
22	625	394	400	835	394	400	297		435.5	487.5	487.5	527.5	527.5	17	213	258
30	625	394	400	835	394	400	297			487.5	487.5	527.5	527.5	17	224	280
37	715.5	394	450	930.5	394	450	297			517.5	557.5	557.5	620.5	15	259	320
45	715.5	394	450	930.5	394	450	297				557.5	557.5	620.5	15	259	320
55	769.5	484	550	-	-	-	412						620.5	29	276	-

Dimensions Reducer Double Reduction 9015 ▶ 9050 P2

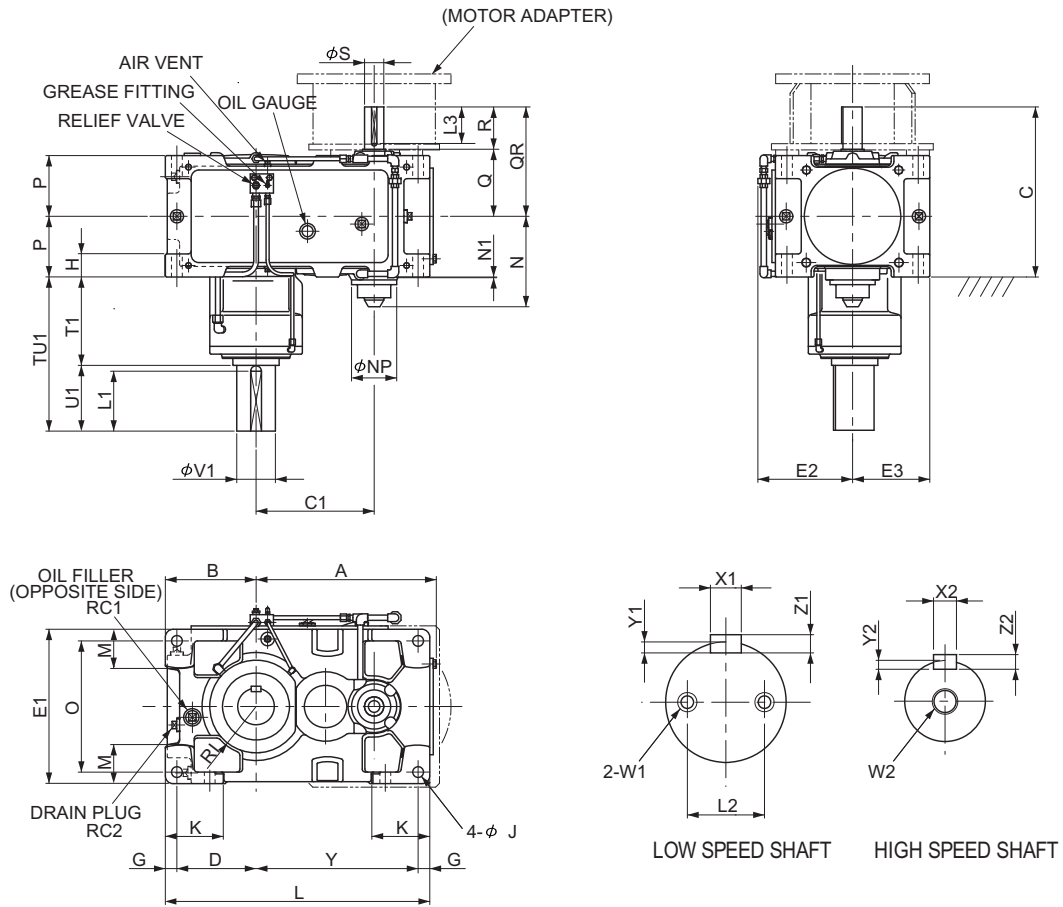

Units : mm

SIZE	A	B	C1	C	D	E1	E2	E3	G	H	RI	J	K	L	M	N	N1	NP	O	P	Y
9015	295	160	194	313.5	140	270	195	135	20	35	80	15	95	440	70	186	14	100	230	102.5	260
9025	346	175	227	343.5	155	310	215	155	20	40	87.5	19	110	505	75	198.5	12	100	270	117.5	310
9030	406	200	264	401.5	175	320	220	160	25	50	105	24	120	590	85	211	9	100	270	132.5	365
9035	437	219	295	401.5	194	370	245	185	25	50	120	24	120	640	100	211	9	100	320	132.5	396
9040	467	235	306	441.5	205	400	260	200	30	60	120	28	150	685	100	237.5	2	117	340	157.5	420
9045	506	256	345	441.5	226	440	266	220	30	60	140	28	150	745	120	237.5	2	117	380	157.5	459
9050	537	255	358	475.5	225	420	270	210	30	60	140	28	150	775	110	257.5	7	117	360	172.5	490

SIZE	RC1	RC2	TU1	T1	U1	V1	W1/Depth	X1	Y1	Z1	L1	L2	QR	Q	R	S	W2/Depth	X2	Y2	Z2	L3	Mass of Reducer (kg)	Oil Qty (L)
9015	3/4"	3/4"	350	240	110	60m6	M10/20	18	7	11	95	42	211	131	80	30k6	M10/22	8	4	7	70	125	5
9025	3/4"	3/4"	384	244	140	70m6	M12/25	20	7.5	12	125	46	226	146	80	35k6	M12/28	10	5	8	70	170	7
9030	3/4"	3/4"	396	226	170	85m6	M12/25	22	9	14	150	55	269	159	110	40k6	M16/36	12	5	8	95	235	9
9035	3/4"	3/4"	406.5	236.5	170	100m6	M16/35	28	10	16	150	60	269	159	110	40k6	M16/36	12	5	8	95	255	12
9040	1"	1"	399	229	170	100m6	M16/35	28	10	16	155	60	284	174	110	50k6	M16/36	14	5.5	9	95	345	18
9045	1"	1"	439	229	210	105m6	M16/35	28	10	16	190	60	284	174	110	50k6	M16/36	14	5.5	9	95	405	22
9050	1"	1"	423.5	214.5	209	110m6	M16/35	28	10	16	190	75	303	193	110	55k6	M20/42	16	6	10	95	485	22

Dimensions Drive Unit Triple Reduction 9015 ▶ 9050 P3

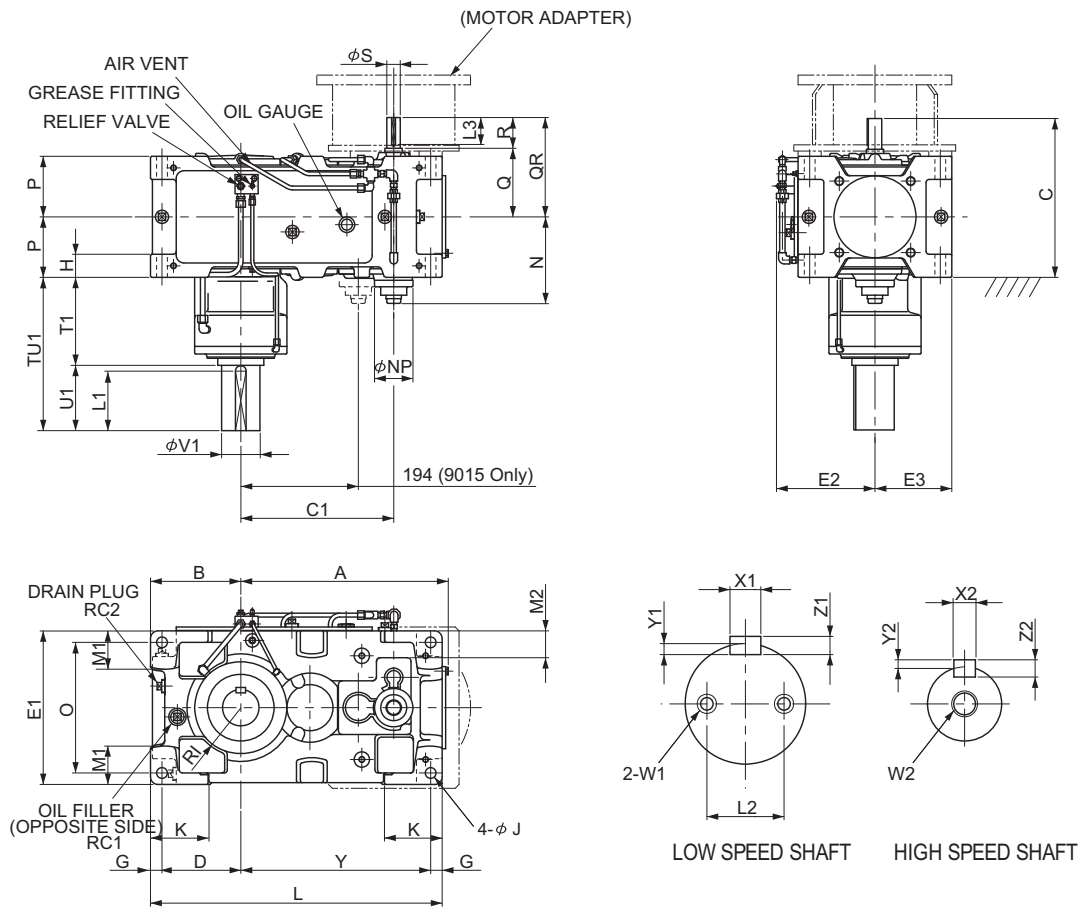

Units : mm

SIZE	A	B	C1	C	D	E1	E2	E3	G	H	RI	J	K	L	M1	M2	N	NP	O	P	Y
9015	338	160	257	292.5	140	270	195	135	20	35	80	15	95	485	70	80	186	100	230	102.5	305
9025	408	175	306	321.5	155	310	215	155	20	40	87.5	19	110	570	75	90	198.5	100	270	117.5	375
9030	453	200	343	373.5	175	320	220	160	25	50	105	24	120	640	85	50	211	100	270	132.5	415
9035	484	219	374	373.5	194	370	245	185	25	50	120	24	120	690	100	75	211	100	320	132.5	446
9040	540	235	398	413.5	205	400	260	200	30	60	120	28	150	759	100	70	228.5	100	340	157.5	494
9045	577	256	437	413.5	226	440	277	220	30	60	140	28	150	819	120	90	228.5	100	380	157.5	533
9050	609	255	467	476.5	225	420	270	210	30	60	140	28	150	848	110	83	248.5	100	360	172.5	563

SIZE	RC1	RC2	TU1	T1	U1	V1	W1/Depth	X1	Y1	Z1	L1	L2	QR	Q	R	S	W2/Depth	X2	Y2	Z2	L3	Mass of Reducer (kg)	Oil Qty (L)
9015	3/4"	3/4"	350	240	110	60m6	M10/20	18	7	11	95	42	190	130	60	25k6	M10/22	8	4	7	50	125	6
9025	3/4"	3/4"	384	244	140	70m6	M12/25	20	7.5	12	125	46	204	144	60	28k6	M10/22	8	4	7	50	175	8
9030	3/4"	3/4"	396	226	170	85m6	M12/25	22	9	14	150	55	241	161	80	30k6	M10/22	8	4	7	70	235	10
9035	3/4"	3/4"	406.5	236.5	170	100m6	M16/35	28	10	16	150	60	241	161	80	30k6	M10/22	8	4	7	70	260	14
9040	1"	1"	399	229	170	100m6	M16/35	28	10	16	155	60	256	176	80	35k6	M12/28	10	5	8	70	340	18
9045	1"	1"	439	229	210	105m6	M16/35	28	10	16	190	60	256	176	80	35k6	M12/28	10	5	8	70	410	22
9050	1"	1"	423.5	214.5	209	110m6	M16/35	28	10	16	190	75	304	194	110	40k6	M16/36	12	5	8	95	490	25

Warranty/Safety Precautions



Warranty

Warranty Period	The warranty period for the Products shall be 18 months after the commencement of delivery or 18 months after the shipment of the Products from the seller's works or 12 months from the Products coming into operation, whichever comes first.
Warranty Condition	<p>In case any problems, troubles or damages on the Products arise due to defects in the Products during the above "Warranty Period", although the Products are appropriately and properly installed in, connected or combined to the equipment or machines, or maintained in accordance with the maintenance manual and are properly operated under the conditions as described in the catalogue or otherwise as agreed upon in writing between the Seller and the Buyer or its customers, the Seller will Provide, at its sole discretion, appropriate repair or replacement on the Products free of charge, except as stipulated in the "Exception for Warranty" as described below.</p> <p>However, in the event that the Products is installed in, connected or combined to or integrated into the equipment or machines, the Seller shall not reimburse the costs for removal or re-installation of the Products or other incidental costs related thereto and any lost opportunity, loss of profit or any other incidental or consequential losses or damages incurred by the Buyer or its customers.</p>
Exception for Warranty	<p>Notwithstanding the above warranty, the warranty as set forth herein shall not be applied to the problems, troubles or damages on the Products which are caused by:</p> <ol style="list-style-type: none"> 1. installations, connections, combinations or integration of the Products in or to other equipment or machines, which are supplied by any person or entity other than the Seller, 2. insufficient maintenance or improper operation by the Buyer or its customers, such that the Product is not appropriately maintained in accordance with the maintenance manual provided or designated by the Seller, 3. improper use or operation of the Products by the Buyer or its customers which are not informed to the Seller, including, without limitation, the Buyer's or its customers' operation of the Products not in conformity with the specifications, or use of the lubrication oil in the Products which is not recommended by the Seller, 4. troubles, problems or damages on any equipment or machines in or to which the Products are installed, connected or combined or installed, or any specifications particular to the Buyer or its customers, or 5. any changes, modifications, improvements or alterations on the Products or those functions which are rendered on the Products by any person or entity other than the Seller, 6. any parts in the Products which are supplied or designated by the Buyer or its customers, 7. earthquake, fire, flood, sea-breeze, gas, thunder, acts of God or any other reasons beyond the control of the Seller, 8. waste, exhaustion, normal wear and tear, or deterioration on the parts of the Products, such as bearing, oil-seal. 9. any other troubles, problems or damages on the Products which are not attributable to the Seller.

SAFETY PRECAUTIONS

- Strictly observe the safety rules necessary for the place of installation and equipment used. (Industrial Safety and Health Law, Technical Standard for Electric Facilities, Extension Rules, Plant Explosion Guidelines, Building Standard Law, etc)
- Carefully read the maintenance manual before use. If the maintenance manual is not on hand, make a request for one to the distributor at which you purchased the product or to our sales department. The maintenance manual should be sent to the actual user.
- Select an appropriate product that matches the operating environment and usage.
- Install a protective equipment on the machine side when the machine is used for transportation of passengers or for elevators, escalators, and dumbwaiters.
- When the machine is used for food processing equipment and others that are susceptible to oil, install an oil pan or other damage preventive devices in case of oil leakage due to failure or termination of service life.

Worldwide Sumitomo Network

U.S.A.

Sumitomo Machinery Corporation of America
4200 Holland Blvd.,
Chesapeake, VA 23323
Tel : (1)757-485-3355
Fax : (1)757-487-3193

Canada

SM-Cyclo of Canada, Ltd.
870 Equestrian Court Oakville,
Ontario, Canada L6L 6L7
Tel : (1)905-469-1050
Fax : (1)905-469-1055

Mexico

SM-Cyclo De Mexico, S.A. de C.V.
Calle "C" No. 506A Parque Industrial
Almacentro Apodaca, N. L., Mexico 66600
Tel : (52)81-8369-3697
Fax : (52)81-8369-3699

Brazil

SM-Cyclo Redutores Do Brasil Ltda.
Av. Fagundes Filho, 191 Metro Sao Judas
Edificio Houston-Sala H123 Sao Paulo-SP
Brazil 04304-010
Tel : (55)11-5585-3600
Fax : (55)11-5585-9990

Chile

SM-Cyclo De Chile, Ltda.
San Pablo Ave, 3507 Quinta Normal,
Santiago, Chile
Tel : (56)2-786-6963
Fax : (56)2-786-6964

Argentina

SM-Cyclo De Argentina S.A.
Montes de Oca #6719, (B1606BMG) Munro,
Buenos Aires, Argentina
Tel : (54)11-4765-5288
Fax : (54)11-4765-5517

United Kingdom

Sumitomo (SHI) Cyclo Drive Europe, Ltd.
Marfleet Kingston upon Hull HU9 5RA,
United Kingdom
Tel : (44)1482-788022
Fax : (44)1482-713205

SM-Cyclo U.K. Ltd.

Marfleet Kingston Upon Hull HU9 5RA,
United Kingdom
Tel : (44)1482-790340
Fax : (44)1482-790321

France

SM-Cyclo France E.U.R.L.
65/75 Avenue Jean Mermoz
F-93126 La Courneuve France
Tel : (33)149-929494
Fax : (33)149-929490

Italy

SM-Cyclo Italy Srl.
Via dell' Artigianato 231-20010
Cornaredo (Mi), Italy
Tel : (39)02-9356-2121
Fax : (39)02-9356-9893

Netherlands

SM-Cyclo Benelux BV
Den Engelsman 16D NL-6026 RB
Maarheeze The Netherlands
Tel : (31)495599777
Fax : (31)495593177

Sweden

SM-Cyclo Scandinavia AB
Företagsvägen 30A S-232 37
Arlöv Sweden
Tel : (46)40430220
Fax : (46)40431001

Spain

SM-Cyclo Iberia,S.L.
C/Landabarrí N^o4 Escalera 1, 2^oizqda Leioa
48940 Vizcaya Spain
Tel : (34)944-805 389
Fax : (34)944-801 550

Germany

Sumitomo (SHI) Cyclo Drive Germany, GmbH
Cyclostraße 92
D-85229 Markt Indersdorf
Tel : (49)8136-66-0
Fax : (49)8136-5771

Austria

SCG Branch Austria Office
Grüntaler straÙe, 30a A-4028 Linz, Austria
Tel : (43)732-330 958
Fax : (43)732-331 978

China

Sumitomo (SHI) Cyclo Drive China, Ltd.
26F, Raffles City, No.268 Xizang
Road Central, Shanghai, 200001 China
Tel : (86)21-6340-4000
Fax : (86)21-6340-3673

Hong Kong

SM-Cyclo of Hong Kong Co., Ltd.
Unit 1802, 18/F., Park Building, 476
Castle Peak Road, Kowloon, Hong Kong
Tel : (852)3529-2093
Fax : (852)2460-1882

Singapore

Sumitomo (SHI) Cyclo Drive
Asia Pacific Pte. Ltd.
No.36 Tuas South Street 3,
Singapore 638031
Tel : (65)6863-2238
Fax : (65)6863-4238

Malaysia

SM-Cyclo of Malaysia Sdn. Bhd.
NO.2, Jalan BP 4/1,
Bandar Bukit Puchong, 47100 Puchong,
Selangor Darul Ehsan, Malaysia.
Tel : (60)3-80612909
Fax : (60)3-80613909

Thailand

SM-Cyclo of Thailand Co., Ltd.
195, Empire Tower
Unit 1504, 15th Floor
South Sathorn Road, Yannawa Sathorn
Bangkok 10120, Thailand
Tel : (66)2-670-0998
Fax : (66)2-670-0999

Vietnam

Representative Office
4th Floor, 99 Nguyen Thi Minh Khai St.
Ward Ben Thanh, District 1, HCM City, Vietnam
Tel : (84)8-925-6504
Fax : (84)8-925-6505

Australia

SM-Cyclo of Australia Pty., Ltd.
9 Holbech Rd., Arndell Park, NSW, 2148
Tel : (61)2-8811-6555
Fax : (61)2-8811-6500

Philippines

Representative Office
Unit 23E Burgundy Corporate Tower
252 Sen. Gil Puyat Ave. Makati City
Tel : (63)2-888-5866
Fax : (63)2-843-0021

India

SCA Liaison Office
759/17, Ramkripa Apartment, Flat No.2,
First Floor Capt. A. Ranade Path,
Deccan Gymkhana, Pune 411004.
Maharashtra, India
Tel : (91)20-2565-3760
Fax : (91)20-2565-3755

Taiwan

Tatung SM-Cyclo Co., Ltd.
22 Chungshan N. Road.,
3rd Sec. Taipei,
Taiwan, 104 R.O.C.
Tel : (886)2-8676-1382
Fax : (886)2-8676-2285

Korea

SM-Cyclo of Korea Co., Ltd.
Royal Bldg. 9F Rm. 913,
5 Dangju-dong Chongro-ku,
Seoul,
Korea 110-721
Tel : (82)2-730-0151
Fax : (82)2-730-0156

Japan

Sumitomo Heavy Industries, Ltd.
9-11, Kitashinagawa 5-Chome
Shinagawa-Ku, Tokyo 141-8686, Japan
Tel : (81)3-5488-8363
Fax : (81)3-5488-8365